

**Qty. Description**

1 CUE 3X380-500V IP20 30KW STO



**Note! Product picture may differ from actual product**

Product No.: On request

CUE is a complete range of external frequency converters designed for speed control of a wide range of Grundfos pumps. CUE has a built-in PI controller and offers the same functionality and user-interface as Grundfos E-pumps. CUE solutions can thus be seen as an extension to the E-pump range.

By choosing a CUE-solution, you will get the following benefits:

- Grundfos E-pump functionality and user-interface
- application- and pump-family-related functions
- increased comfort compared to fixed-speed pumps
- very easy installation and commissioning compared to standard frequency converters
- speed control of pumps up to 250 kW
- speed control of pumps installed in potentially explosive environments.

CUE offers the following inputs and output:

- RS-485 GENIbus
- an analog 0-10 V input for external setpoint
- an analog 0/4-20 mA input for sensor
- four digital inputs for various functions, for instance external start/stop
- two signal relays (C/NO/NC).

Accessories:

Input/output add-on board

Provides additional input:

- one 0/4-20 mA analog input for an additional sensor
- one 0-20 mA analog output
- two inputs for Pt100/Pt1000 temperature sensors, for instance for bearing monitoring.

Motor filters:

For reduction of dU/dt and peak voltages to the motor windings and for reduction of the acoustic noise generated in the motor, a number of motor filters are offered:

- dU/dt filters , 11-250 kW
- Sine wave filters, 0.55-250 kW.

Technical:

Approvals on nameplate: CE, CULUS, C-TICK

Installation:

Range of ambient temperature: 0 .. 45 °C

Relative humidity: 5-95 %

Electrical data:

Rated power - P2: 30 kW  
Mains frequency: 50 / 60 Hz  
Rated voltage [V]: 3 x 380-440/441-500 V  
Rated current: 61-52 A  
Maximum current consumption: 61 A  
Efficiency at full load: 98 %  
Enclosure class (IEC 34-5): IP20



Company name:

Created by:

Phone:

Date:

17/06/2022

Qty.	Description
	<p data-bbox="194 333 288 367">Others:</p> <p data-bbox="194 365 651 400">Net weight: 23.5 kg</p>

Description	Value
<b>General information:</b>	
Product name:	CUE 3X380-500V IP20 30KW STO
Product No:	On request
EAN number:	On request
<b>Technical:</b>	
Approvals on nameplate:	CE, CULUS, C-TICK
<b>Installation:</b>	
Range of ambient temperature:	0 .. 45 °C
Relative humidity:	5-95 %
Mounted on:	Wall
<b>Electrical data:</b>	
Rated power - P2:	30 kW
Mains frequency:	50 / 60 Hz
Rated voltage [V]:	3 x 380-440/441-500 V
Rated current:	61-52 A
Maximum current consumption:	61 A
Efficiency at full load:	98 %
Enclosure class (IEC 34-5):	IP20
Built-in motor protection:	YES
Thermal protec:	external
Cable length:	150/300 m
<b>Others:</b>	
Net weight:	23.5 kg

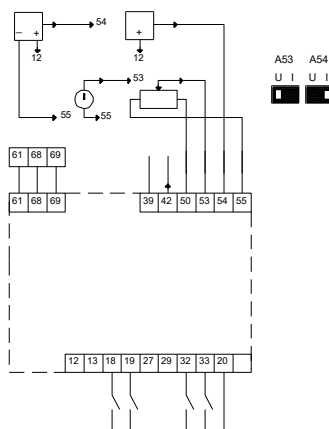
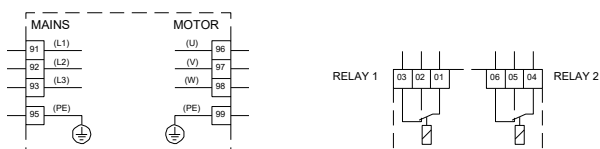
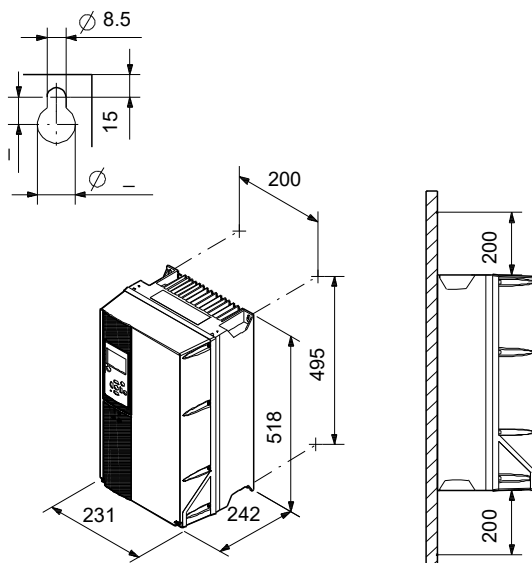

## On request CUE 3X380-500V IP20 30KW STO

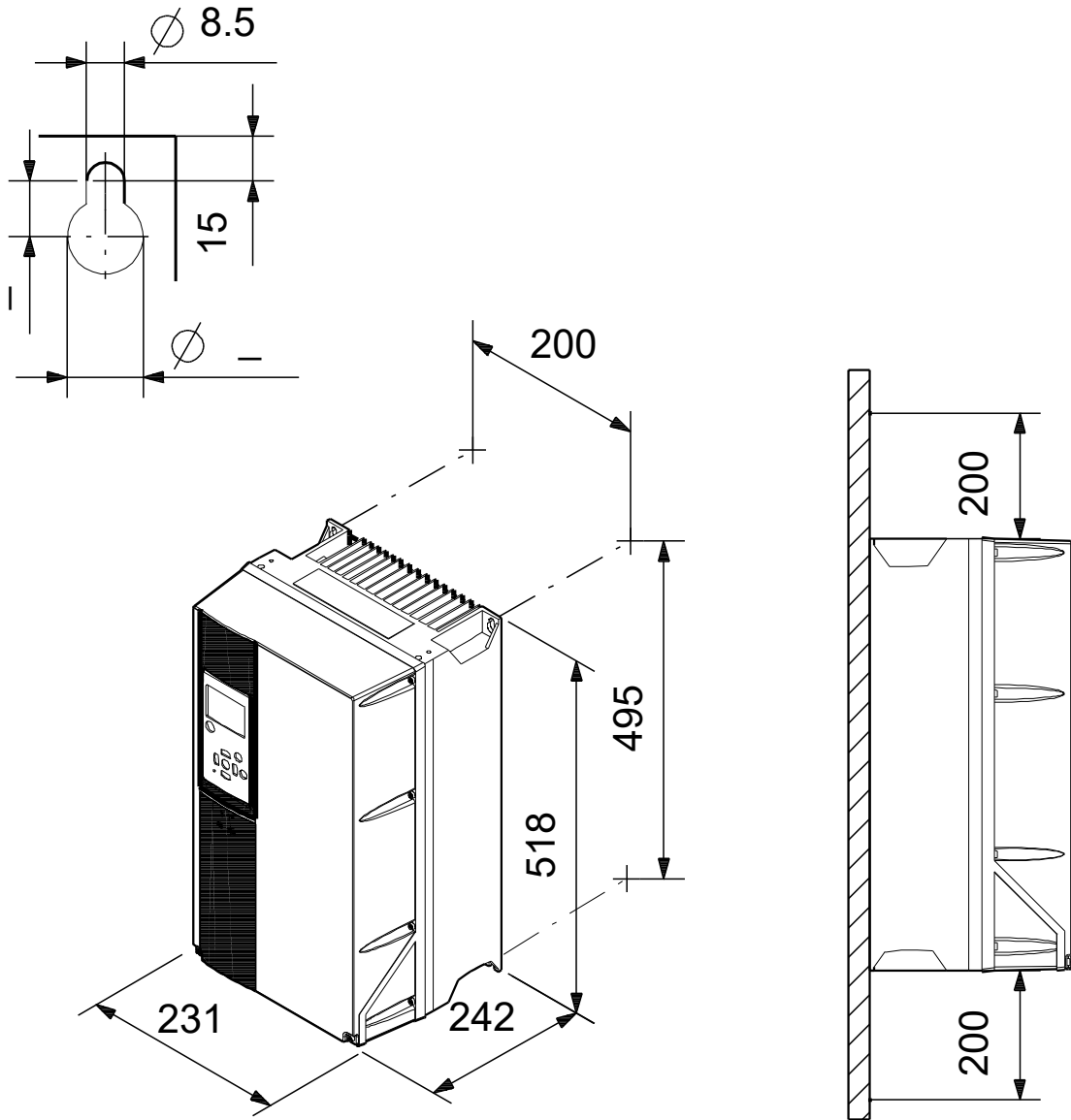

Note! All units are in [mm] unless others are stated.  
Disclaimer: This simplified dimensional drawing does not show all details.



Company name:

Created by:

Phone:

Date:

17/06/2022

---

**Order Data:**

Product name: CUE 3X380-500V IP20 30KW STO

Amount: 1

Product No: On request

Total: Price on request

---