

Qty. Description

1 CRE 95-1-1 A-F-A-E-HQQE



Note! Product picture may differ from actual product

Product No.: [99264346](#)

Vertical, multistage centrifugal pump with inlet and outlet ports on same the level (inline). The pump head and base are in cast iron – all other wetted parts are in stainless steel. The Grundfos cartridge shaft seal ensures high reliability, safe handling, and easy access and service. Power transmission is via a rigid split coupling. Pipe connection is via DIN flanges.

The pump is fitted with a 3-phase, fan-cooled, permanent-magnet, synchronous motor.

The motor efficiency is classified as IE5 in accordance with IEC 60034-30-2.

The motor includes a frequency converter and PI controller in the motor terminal box. This enables continuously variable control of the motor speed, which again enables adaptation of the performance to a given requirement.

The terminal box has a number of inputs and outputs enabling the motor to be used in advanced applications where many inputs and outputs are required:

- two dedicated digital inputs
- three analog inputs, 0(4)-20 mA, 0-5 V, 0-10 V, 0.5 - 3.5 V
- 5 V voltage supply to potentiometer and sensor
- one analog output, 0-10 V, 0(4)-20 mA
- two configurable digital inputs or open-collector outputs
- two Pt100/Pt1000 inputs
- LiqTec, dry-running protection sensor input
- Grundfos Digital Sensor input and output
- 24 V voltage supply for sensors
- two signal-relay outputs (potential-free contacts)
- GENIbus connection
- interface for Grundfos CIM fieldbus module.

Further product details

An external sensor can be connected if controlled pump operation based on for example flow, differential pressure or temperature is required.

Steel, cast iron and aluminium components have an epoxy-based coating made in a cathodic electro-deposition (CED) process.

CED is a high-quality dip-painting process where an electrical field around the products ensures deposition of paint particles as a thin, well-controlled layer on the surface.

An integral part of the process is a pretreatment.

The entire process consists of these elements:

- 1) Alkaline-based cleaning.
- 2) Zinc phosphating.
- 3) Cathodic electro-deposition.
- 4) Curing to a dry film thickness 18-22 my m.

The colour code for the finished product is NCS 9000/RAL 9005.

Pump

A long split coupling connects the pump and motor shaft. It is enclosed in the motor stool by means of two coupling guards. The long coupling makes it possible to replace the shaft seal without removing the motor from the pump.

Qty. Description

1

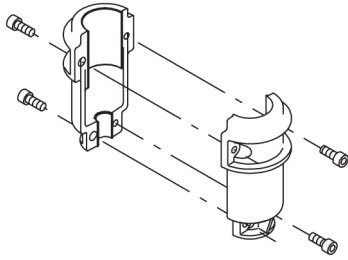

The motor stool connects the pump head and motor. The pump head has a combined 1/2" priming plug and vent screw.

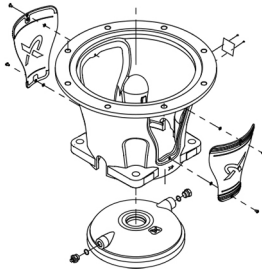

The pump is fitted with a balanced O-ring seal unit with a rigid torque-transmission system.

This seal type is assembled in a cartridge unit which makes replacement safe and easy.

Due to the balancing, this seal type is suitable for high-pressure applications.

The cartridge construction also protects the pump shaft from possible wear from a dynamic O-ring between pump shaft and shaft seal.

Seal faces:

- Rotating seal ring material: silicon carbide (SiC)
- Stationary seat material: silicon carbide (SiC)

This material pairing is used where higher corrosion resistance is required. The high hardness of this material pairing offers good resistance against abrasive particles.

Secondary seal material: EPDM (ethylene-propylene rubber)

EPDM has excellent resistance to hot water. EPDM is not suitable for mineral oils.

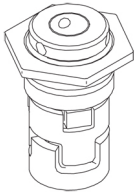

The shaft seal is screwed into the pump head.

The chambers and impellers are made of stainless-steel sheet. The chambers are provided with a PEEK neck ring offering improved sealing and high efficiency. The impellers have smooth surfaces, and the shape of the blades ensure a high efficiency.

The base is made of cast iron and mounted on a separate cast-iron base plate.

Both the inlet and the outlet side of the base have two pressure gauge tapings.

The pump is secured to the foundation by four bolts through the base plate.

The flanges are fastened to the base by means of locking rings.

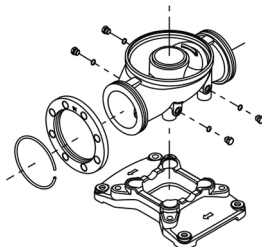

Qty.	Description
1	<p>Motor</p> <p>The motor is a totally enclosed, fan-cooled motor with principal dimensions to IEC and DIN standards. The motor is flange-mounted with free-hole flange (FF).</p> <p>Motor-mounting designation in accordance with IEC 60034-7: IM B 5 (Code I) / IM 3001 (Code II).</p> <p>Electrical tolerances comply with IEC 60034.</p> <p>The motor efficiency is classified as IE5 in accordance with IEC 60034-30-2.</p> <p>The motor requires no external motor protection. The motor control unit incorporates protection against slow- and quick-rising temperatures, e.g. constant overload and stalled conditions.</p> <p>The terminal box has a number of inputs and outputs enabling the motor to be used in advanced applications where many inputs and outputs are required:</p> <ul style="list-style-type: none"> • two dedicated digital inputs • three analog inputs, 0(4)-20 mA, 0-5 V, 0-10 V, 0.5 - 3.5 V • 5 V voltage supply to potentiometer and sensor • one analog output, 0-10 V, 0(4)-20 mA • two configurable digital inputs or open-collector outputs • two Pt100/Pt1000 inputs • LiqTec, dry-running protection sensor input • Grundfos Digital Sensor input and output • 24 V voltage supply for sensors • two signal-relay outputs (potential-free contacts) • GENIbus connection • interface for Grundfos CIM fieldbus module. <p>Technical data</p> <p>Liquid: Pumped liquid: Water Liquid temperature range: -20 .. 120 °C Selected liquid temperature: 20 °C Density: 998.2 kg/m³</p> <p>Technical: Pump speed on which pump data are based: 3555 rpm Rated flow: 114 m³/h Rated head: 23.6 m Pump orientation: Vertical Shaft seal arrangement: Single Code for shaft seal: HQQE Approvals: CE,EAC,UKCA,SEPRO Approvals for drinking water: ACS Curve tolerance: ISO9906:2012 3B</p> <p>Materials: Base: Ductile cast iron EN 1563 EN-GJS-500-7 ASTM A536-84 65-45-12 Impeller: Stainless steel EN 1.4301 AISI 304 Bearing: WC/WC Support bearing: Graflon Material certified according to: European standards</p> <p>Installation: t max amb: 50 °C Maximum operating pressure: 16 bar Max pressure at stated temp: 16 bar / 120 °C Type of connection: DIN Size of inlet connection: DN 100</p>

Qty. Description

1	Size of outlet connection: DN 100
	Pressure rating for connection: PN 16
	Flange size for motor: FF300
	Electrical data:
	Motor standard: IEC
	Motor type: 160MH
	IE Efficiency class: IE5
	Rated power - P2: 11 kW
	Power (P2) required by pump: 11 kW
	Over/undersize motor: Standard motor size
	Mains frequency: 50 / 60 Hz
	Rated voltage: 3 x 380-500 V
	Rated current: 20.3-16.0 A
	Cos phi - power factor: 0.93-0.90
	Rated speed: 360-4000 rpm
	Efficiency: 93.1%
	Motor efficiency at full load: 93.1 %
	Enclosure class (IEC 34-5): IP55
	Insulation class (IEC 85): F
	Motor No: 98971053
	Controls:
	Frequency converter: Built-in
	Pressure sensor: N
	Others:
	Minimum efficiency index, MEI \geq : 0.70
	Net weight: 158 kg
	Gross weight: 208 kg
	Shipping volume: 0.611 m ³
	Danish VVS No.: 385949811
	Thrust handling device: N

99264346 CRE 95-1-1 A-F-A-E-HQQE

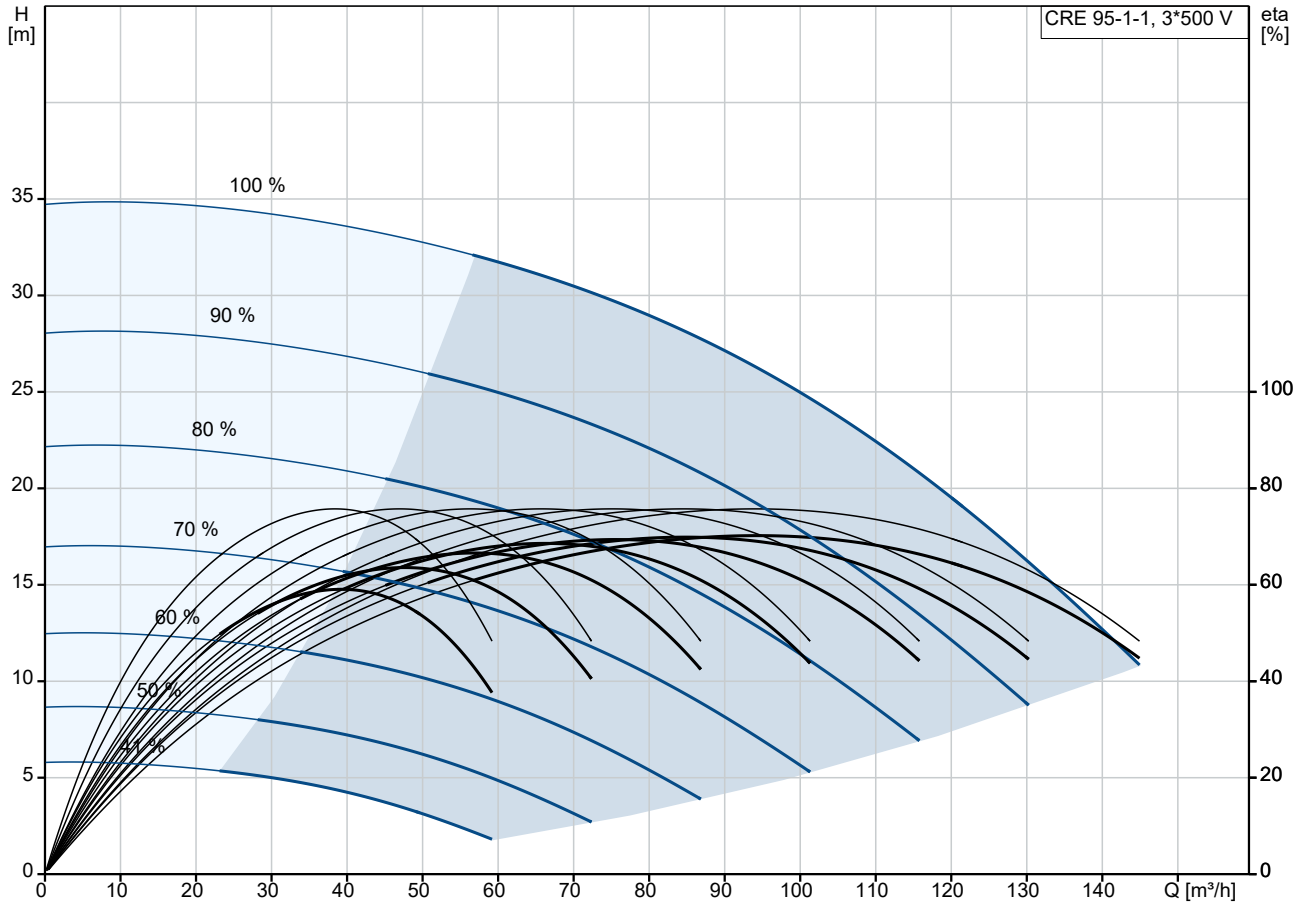

Pumped liquid = Water
 Liquid temperature during operation = 20 °C
 Density = 998.2 kg/m³

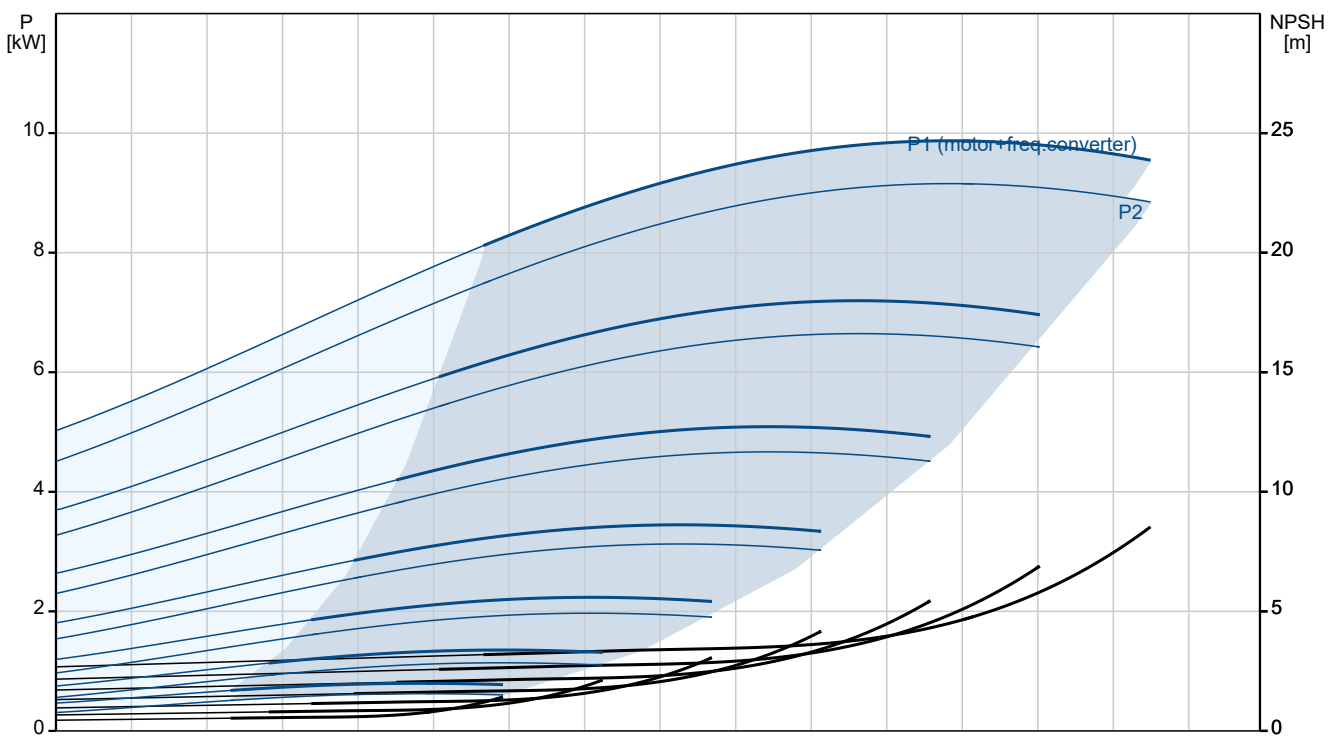

Description	Value
General information:	
Product name:	CRE 95-1-1 A-F-A-E-HQQE
Product No:	99264346
EAN number:	5713826222673
Technical:	
Pump speed on which pump data are based:	3555 rpm
Rated flow:	114 m ³ /h
Rated head:	23.6 m
Maximum head:	36.4 m
Impellers:	1
Number of reduced-diameter impellers:	1
Low NPSH:	N
Pump orientation:	Vertical
Shaft seal arrangement:	Single
Code for shaft seal:	HQQE
Approvals:	CE,EAC,UKCA,SEPRO
Approvals for drinking water:	ACS
Curve tolerance:	ISO9906:2012 3B
Pump version:	A
Model:	A
Materials:	
Base:	Ductile cast iron
Base:	EN 1563 EN-GJS-500-7
Base:	ASTM A536-84 65-45-12
Impeller:	Stainless steel
Impeller:	EN 1.4301
Impeller:	AISI 304
Material code:	A
Code for rubber:	E
Bearing:	WC/WC
Support bearing:	Graflon
Material certified according to:	European standards
Installation:	
t max amb:	50 °C
Maximum operating pressure:	16 bar
Max pressure at stated temp:	16 bar / 120 °C
Type of connection:	DIN
Size of inlet connection:	DN 100
Size of outlet connection:	DN 100
Pressure rating for connection:	PN 16
Flange size for motor:	FF300
Connect code:	F
Liquid:	
Pumped liquid:	Water
Liquid temperature range:	-20 .. 120 °C
Selected liquid temperature:	20 °C
Density:	998.2 kg/m ³
Electrical data:	
Motor standard:	IEC
Motor type:	160MH
IE Efficiency class:	IE5
Rated power - P2:	11 kW
Power (P2) required by pump:	11 kW
Over/undersize motor:	Standard motor size
Mains frequency:	50 / 60 Hz
Rated voltage:	3 x 380-500 V

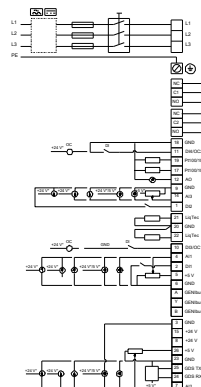
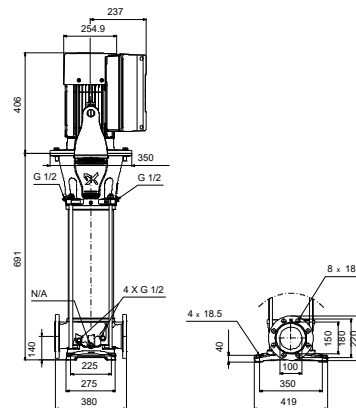
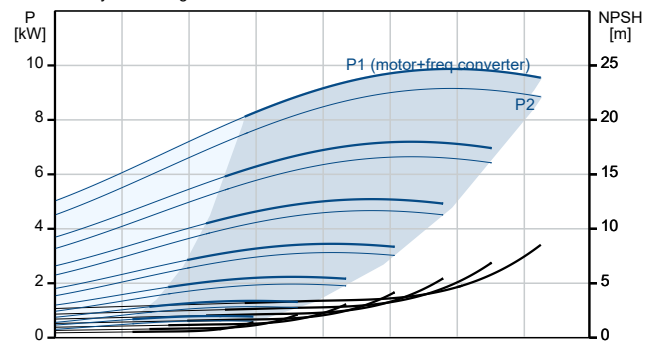
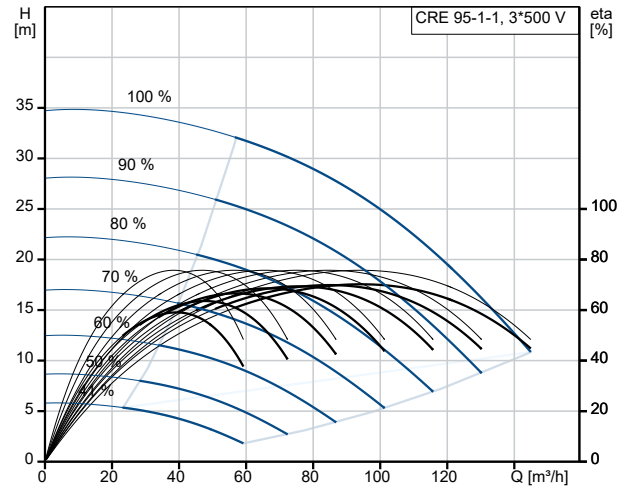



Company name:

Created by:

Phone:

Date:

29/12/2022

Description	Value
Rated current:	20.3-16.0 A
Cos phi - power factor:	0.93-0.90
Rated speed:	360-4000 rpm
Efficiency:	93.1%
Motor efficiency at full load:	93.1 %
Enclosure class (IEC 34-5):	IP55
Insulation class (IEC 85):	F
Built-in motor protection:	ELEC
Motor No:	98971053
Controls:	
Function Module:	FM300 - Advanced
Frequency converter:	Built-in
Pressure sensor:	N
Others:	
Minimum efficiency index, MEI \geq :	0.70
Net weight:	158 kg
Gross weight:	208 kg
Shipping volume:	0.611 m ³
Config. file no:	99059432
Danish VVS No.:	385949811
Thrust handling device:	N

99264346 CRE 95-1-1 A-F-A-E-HQQE

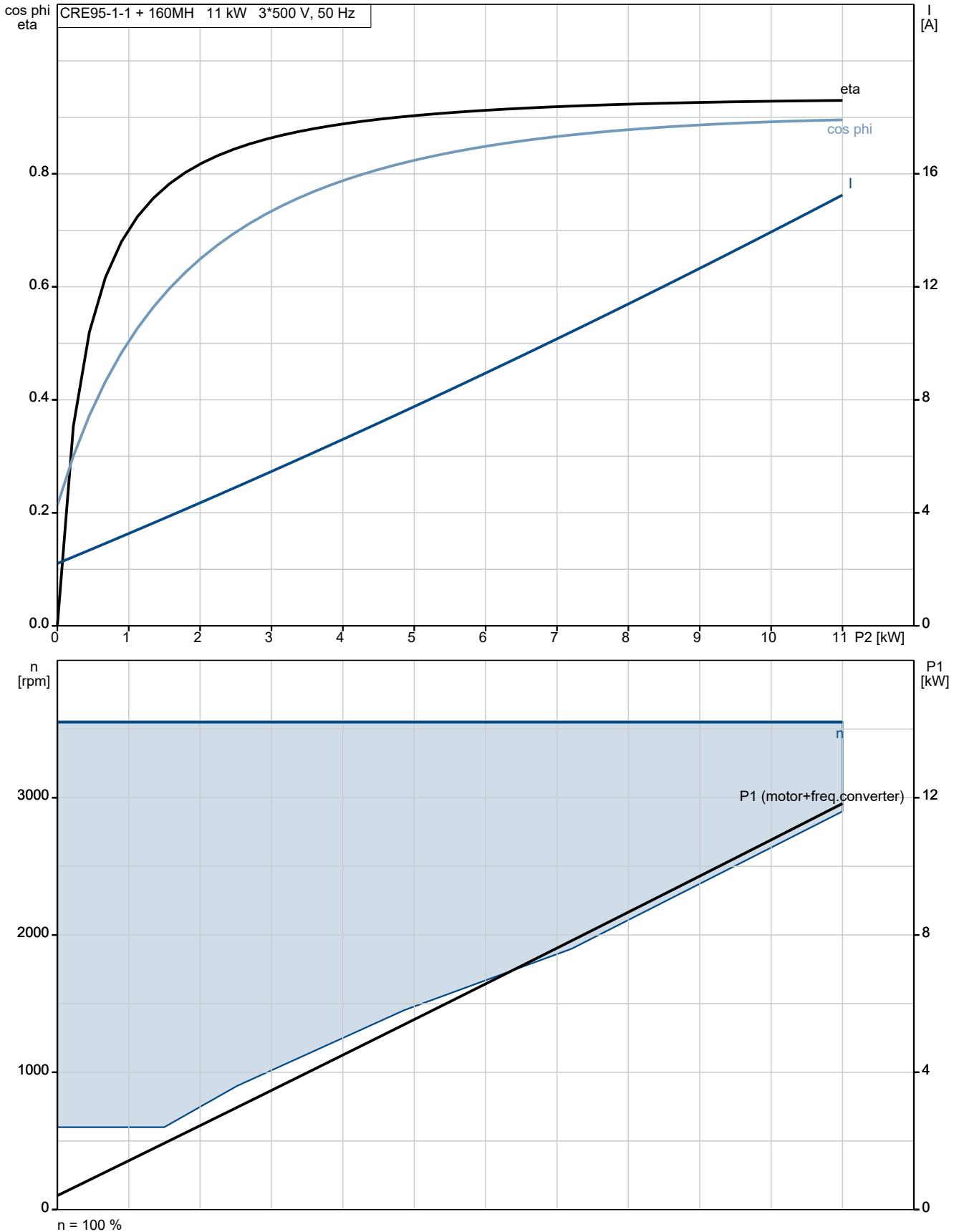

99264346 CRE 95-1-1 A-F-A-E-HQQE

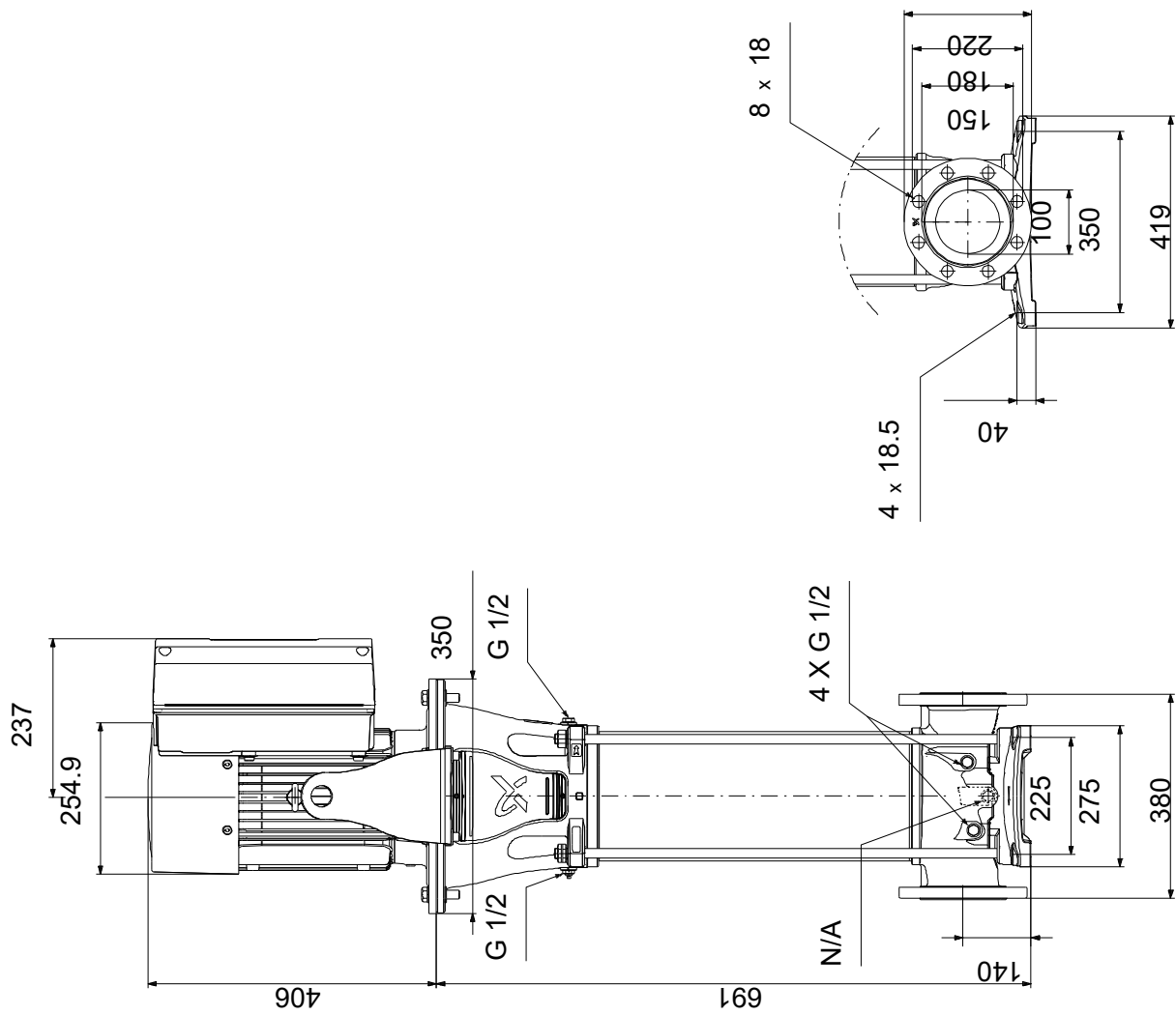

Note! All units are in [mm] unless others are stated.
Disclaimer: This simplified dimensional drawing does not show all details.

99264346 CRE 95-1-1 A-F-A-E-HQQE



Note! All units are in [mm] unless others are stated.



Company name:
Created by:
Phone:

Date: 29/12/2022

Order Data:

Position	Your pos.	Product name	Amount	Product No	Total
		CRE 95-1-1	1	99264346	Price on request