

Qty. Description1 **TPED 100-120/2 S-A-F-A-BQQE-IDB****Note! Product picture may differ from actual product**

Product No.: On request

Single-stage, close-coupled, volute twin-head pump with in-line suction and discharge ports of identical diameter. The twin-head pump is designed with two parallel power-heads.

The pump is of the top-pull-out design, i.e. the power head (motor, pump head and impeller) can be removed for maintenance or service while the pump housing remains in the pipework.

Each power head is fitted with an unbalanced rubber bellows seal.

The shaft seal is according to EN 12756. Pipework connection is via PN 10 DIN flanges (EN 1092-2 and ISO 7005-2).

Each power head is fitted with a fan-cooled, permanent-magnet synchronous motor of identical size. The motor efficiency is classified as IE5 in accordance with IEC 60034-30-2.

The motor includes a frequency converter and PI controller in the motor terminal box. This enables continuously variable control of the motor speed, which again enables adaptation of the performance to a given requirement.

The pump is fitted with a differential pressure sensor.

The pump is suitable for applications requiring pressure control. The pump is fitted with a differential-pressure transmitter registering the differential pressure across the pump and enabling constant pressure or proportional-pressure control of the pump.

A cable ensures communication between the two power heads. The selector switch in the terminal boxes enables changeover between the operating modes "alternating operation" and "standby operation".

The product's minimum efficiency index (MEI) is greater or equal to 0.70. This is by the Commission Regulation (EU) considered as an indicative benchmark for best-performing water pump available on the market as from 1 January 2013.

The operating panel on the motor terminal box features a four-inch TFT display, push-buttons and the Grundfos Eye indicator.

The display gives an intuitive and user-friendly interface to all functions.

The push-buttons are used to navigate through the menu structure to access pump and performance data on site and enable setting of required setpoint as well as setting of pump to "Min." or "Max." operation or to "Stop".

The Grundfos Eye indicator on the operating panel provides visual indication of pump status:

- "Power on": Motor is running (rotating green indicator lights) or not running (permanently green indicator lights)
- "Warning": Motor is still running (rotating yellow indicator lights) or has stopped (permanently yellow indicator lights)
- "Alarm": Motor has stopped (flashing red indicator lights).

Communication with the pump is also possible by means of Grundfos GO Remote (accessory). The remote control enables further settings as well as reading out of a number of parameters such as "Actual value", "Speed", "Power input" and total "Power consumption".

A control panel enables setting of required setpoint as well as setting of pump to "Min." or "Max." operation or to "Stop".

The control panel has indicator lights for "Operation" and "Fault".

Communication with the pump is possible by means of the Grundfos GO Remote (accessory).

The remote control enables further settings as well as reading out of a number of parameters such as "Actual value", "Speed", "Power input" and total "Power consumption".

Cast-iron parts have an epoxy-based coating made in a cathodic electro-deposition (CED) process. CED is a high-quality dip-painting process where an electrical field around the products ensures deposition of paint particles as a thin, well-controlled layer on the surface.

Pump

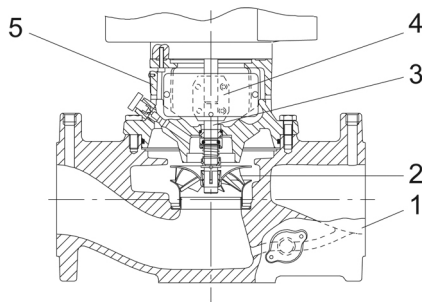

- 1: Pump housing
- 2: Impeller
- 3: Shaft
- 4: Coupling
- 5: Pump head

The twin-head pump is designed with two parallel power-heads. A flap valve in the common discharge port is opened by the flow of the pumped liquid and prevents backflow of liquid into the idle pump head.

The pump housing is provided with a replaceable stainless steel/PTFE neck ring to reduce the amount of liquid running from the discharge side of the impeller to the suction side.

The impeller is secured with a split cone with nut.

The pump is fitted with an unbalanced rubber bellows seal with torque transmission across the spring and around the bellows. Due to the bellows, the seal does not wear the shaft, and the axial movement is not prevented by deposits on the shaft.

Seal faces:

- Rotating seal ring material: silicon carbide (SiC)
- Stationary seat material: silicon carbide (SiC)

This material pairing is used where higher corrosion resistance is required. The high hardness of this material pairing offers good resistance against abrasive particles.

Secondary seal material: EPDM (ethylene-propylene rubber)

EPDM has excellent resistance to hot water. EPDM is not suitable for mineral oils.

A circulation of liquid through the duct of the air vent screw ensures lubrication and cooling of the shaft seal.

The pump housing has two Rp 1/8 tappings for mounting of automatic air vents. Fit an air vent to the upper pump housing if the twin-head pump is to be installed in a horizontal pipeline with horizontal pump shaft.

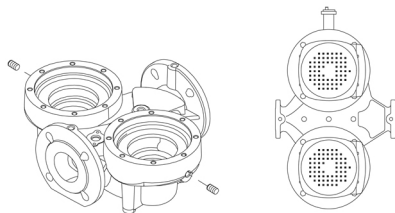

The flanges have tappings for mounting of pressure gauges.

The motor stool forms connection between the pump housing and the motor, and is equipped with a manual air vent screw for venting of the pump housing and the shaft seal chamber. The sealing between motor stool and pump housing is an O-ring.

The central part of the motor stool is provided with guards for protection against the shaft and coupling. Motor and pump shaft are connected via a shell coupling.

Motor

The motor is a totally enclosed, fan-cooled motor with principal dimensions to IEC and DIN standards. Electrical tolerances comply with IEC 60034.

The motor is flange-mounted with tapped-hole flange (FT).

Motor-mounting designation in accordance with IEC 60034-7: IM B 14, IM V 18 (Code I) / IM 3601, IM 3611 (Code II).

The motor efficiency is classified as IE5 in accordance with IEC 60034-30-2.

The motor requires no external motor protection. The motor control unit incorporates protection against slow- and quick-rising temperatures, e.g. constant overload and stalled conditions.

The terminal box holds terminals for these connections:

Qty.	Description
	<ul style="list-style-type: none"> • one dedicated digital input • two analog inputs, 0(4)-20 mA, 0-5 V, 0-10 V, 0.5 - 3.5 V; the factory-fitted pressure sensor is connected to one of these inputs • 5 V voltage supply to potentiometer and sensor • one configurable digital input or open-collector output • Grundfos Digital Sensor input and output • 24 V voltage supply for sensors • two signal relay outputs (potential-free contacts) • the two power heads communicate via wireless GENIair or wired GENI connection • interface for Grundfos CIM fieldbus module. <p>Further product details</p> <p>Cast-iron parts have an epoxy-based coating made in a cathodic electro-deposition (CED) process. CED is a high-quality dip-painting process where an electrical field around the products ensures deposition of paint particles as a thin, well-controlled layer on the surface.</p> <p>Technical data</p> <p>Controls:</p> <p>Frequency converter: Built-in</p> <p>Liquid:</p> <p>Pumped liquid: Water</p> <p>Liquid temperature range: -25 .. 120 °C</p> <p>Selected liquid temperature: 20 °C</p> <p>Density: 998.2 kg/m³</p> <p>Technical:</p> <p>Pump speed on which pump data are based: 2910 rpm</p> <p>Rated flow: 72.8 m³/h</p> <p>Rated head: 7.79 m</p> <p>Actual impeller diameter: 104 mm</p> <p>Code for shaft seal: BQQE</p> <p>Curve tolerance: ISO9906:2012 3B2</p> <p>Materials:</p> <p>Pump housing: Cast iron EN-GJL-250 ASTM class 35</p> <p>Impeller: Stainless steel EN 1.4301 AISI 304</p> <p>Installation:</p> <p>Range of ambient temperature: -20 .. 50 °C</p> <p>Maximum operating pressure: 10 bar</p> <p>Max pressure at stated temp: 10 bar / 120 °C</p> <p>Type of connection: DIN</p> <p>Size of connection: DN 100</p> <p>Pressure rating for connection: PN 10</p> <p>Port-to-port length: 450 mm</p> <p>Flange size for motor: FT115</p> <p>Electrical data:</p> <p>Motor type: 90LD</p> <p>IE Efficiency class: IE5</p> <p>Rated power - P2: 2.2 kW</p> <p>Mains frequency: 50 Hz</p>



Company name:

Created by:

Phone:

Date:

16/06/2022

Qty.	Description
	Rated voltage: 3 x 380-500 V
	Rated current: 4.15-3.40 A
	Cos phi - power factor: 0.93-0.87
	Rated speed: 360-4000 rpm
	Efficiency: 90.1%
	Motor efficiency at full load: 90.1 %
	Number of poles: 2
	Enclosure class (IEC 34-5): IP55
	Insulation class (IEC 85): F
	Motor No: 98362282
	Others:
	Minimum efficiency index, MEI \geq : 0.70
	Net weight: 109 kg
	Gross weight: 131 kg
	Shipping volume: 0.39 m ³
	Country of origin: HU
	Custom tariff no.: 84137065

Description	Value
General information:	
Product name:	TPED 100-120/2 S-A-F-A-BQQE-IDB
Product No:	On request
EAN number:	On request
Technical:	
Pump speed on which pump data are based:	2910 rpm
Rated flow:	72.8 m ³ /h
Rated head:	7.79 m
Maximum head:	120 dm
Actual impeller diameter:	104 mm
Code for shaft seal:	BQQE
Curve tolerance:	ISO9906:2012 3B2
Pump version:	A
Materials:	
Pump housing:	Cast iron
Pump housing:	EN-GJL-250
Pump housing:	ASTM class 35
Impeller:	Stainless steel
Impeller:	EN 1.4301
Impeller:	AISI 304
Material code:	A
Installation:	
Range of ambient temperature:	-20 .. 50 °C
Maximum operating pressure:	10 bar
Max pressure at stated temp:	10 bar / 120 °C
Type of connection:	DIN
Size of connection:	DN 100
Pressure rating for connection:	PN 10
Port-to-port length:	450 mm
Flange size for motor:	FT115
Connect code:	F
Liquid:	
Pumped liquid:	Water
Liquid temperature range:	-25 .. 120 °C
Selected liquid temperature:	20 °C
Density:	998.2 kg/m ³
Electrical data:	
Motor type:	90LD
IE Efficiency class:	IE5
Rated power - P2:	2.2 kW
Mains frequency:	50 Hz
Rated voltage:	3 x 380-500 V
Rated current:	4.15-3.40 A
Cos phi - power factor:	0.93-0.87
Rated speed:	360-4000 rpm
Efficiency:	90.1%
Motor efficiency at full load:	90.1%
Number of poles:	2
Enclosure class (IEC 34-5):	IP55
Insulation class (IEC 85):	F
Built-in motor protection:	ELEC
Motor No:	98362282
Controls:	
Control panel:	HMI300 - Graphical
Function Module:	FM300 - Advanced
Frequency converter:	Built-in
Others:	

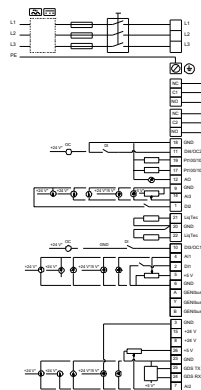
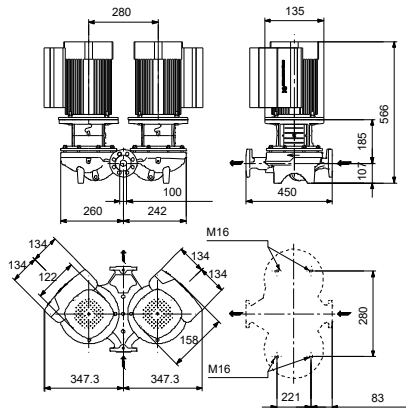
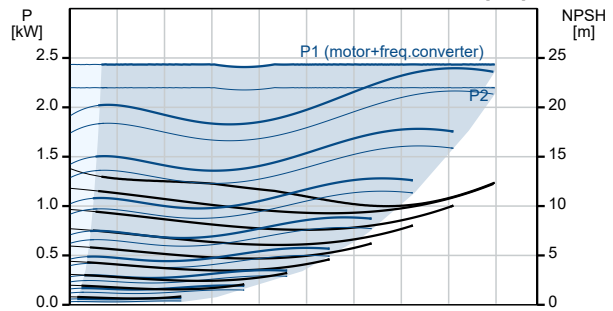
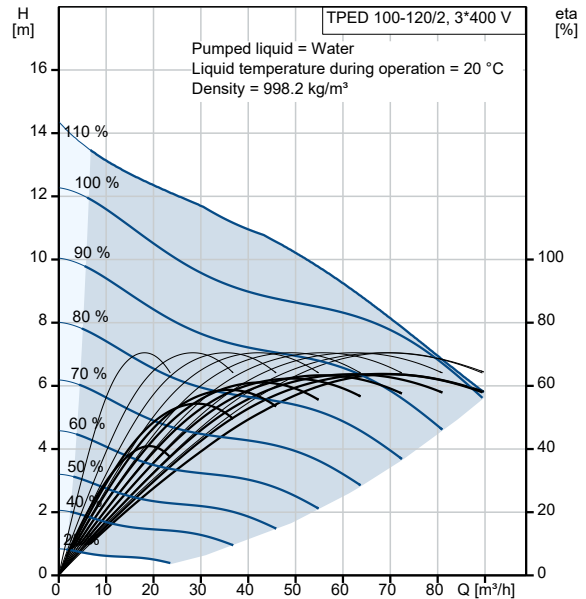



Company name:

Created by:

Phone:

Date:

16/06/2022

Description	Value
Minimum efficiency index, MEI ≥:	0.70
Net weight:	109 kg
Gross weight:	131 kg
Shipping volume:	0.39 m ³
Config. file no:	99140384
Country of origin:	HU
Custom tariff no.:	84137065



Company name:

Created by:

Phone:

Date:

16/06/2022

Order Data:

Product name: TPED 100-120/2

Amount: 1

Product No: On request

Total: Price on request
