

Qty.	Description
1	TPED 100-200/4 S-A-F-A-BQQE-MDA
	
	<p>Note! Product picture may differ from actual product</p>
	<p>Product No.: On request</p>
	<p>Single-stage, close-coupled, volute twin-head pump with in-line suction and discharge ports of identical diameter. The twin-head pump is designed with two parallel power-heads.</p>
	<p>The pump is of the top-pull-out design, i.e. the power head (motor, pump head and impeller) can be removed for maintenance or service while the pump housing remains in the pipework.</p>
	<p>Each power head is fitted with an unbalanced rubber bellows seal.</p>
	<p>The shaft seal is according to EN 12756. Pipework connection is via PN 16 DIN flanges (EN 1092-2 and ISO 7005-2).</p>
	<p>Each power head is fitted with a fan-cooled, permanent-magnet synchronous motor of identical size. The motor efficiency is classified as IE5 in accordance with IEC 60034-30-2.</p>
	<p>The motor includes a frequency converter and PI controller in the motor terminal box. This enables continuously variable control of the motor speed, which again enables adaptation of the performance to a given requirement.</p>
	<p>The pump is fitted with a differential pressure sensor.</p>
	<p>Controls:</p>
	<p>Frequency converter: Built-in</p>
	<p>Liquid:</p>
	<p>Pumped liquid: Water</p>
	<p>Liquid temperature range: -25 .. 120 °C</p>
	<p>Selected liquid temperature: 20 °C</p>
	<p>Density: 998.2 kg/m³</p>
	<p>Technical:</p>
	<p>Pump speed on which pump data are based: 1455 rpm</p>
	<p>Rated flow: 92 m³/h</p>
	<p>Rated head: 16.7 m</p>
	<p>Actual impeller diameter: 240 mm</p>
	<p>Code for shaft seal: BQQE</p>
	<p>Curve tolerance: ISO9906:2012 3B2</p>
	<p>Materials:</p>
	<p>Pump housing: Cast iron EN-GJL-250 ASTM class 35</p>
	<p>Impeller: Cast iron EN-GJL-200 ASTM class 30</p>
	<p>Installation:</p>
	<p>Range of ambient temperature: -20 .. 50 °C</p>
	<p>Maximum operating pressure: 16 bar</p>
	<p>Max pressure at stated temp: 16 bar / 120 °C</p>
	<p>Type of connection: DIN</p>
	<p>Size of connection: DN 100</p>
	<p>Pressure rating for connection: PN 16</p>
	<p>Port-to-port length: 670 mm</p>
	<p>Flange size for motor: FF265</p>
	<p>Electrical data:</p>
	<p>Motor type: 132MH</p>
	<p>IE Efficiency class: IE5</p>

Qty.	Description
1	<p>Rated power - P2: 7.5 kW Mains frequency: 50 Hz Rated voltage: 3 x 380-500 V Rated current: 14.1-11.1 A Cos phi - power factor: 0.93-0.89 Rated speed: 180-2200 rpm Efficiency: 92.2% Motor efficiency at full load: 92.2 % Number of poles: 4 Enclosure class (IEC 34-5): IP55 Insulation class (IEC 85): F Motor No: 98971268</p> <p>Others: Minimum efficiency index, MEI ≥: 0.45 Net weight: 423 kg Gross weight: 532 kg Shipping volume: 1.53 m³ Country of origin: HU Custom tariff no.: 84137065</p>

Description	Value
General information:	
Product name:	TPED 100-200/4 S-A-F-A-BQQE-MDA
Product No:	On request
EAN number:	On request
Technical:	
Pump speed on which pump data are based:	1455 rpm
Rated flow:	92 m³/h
Rated head:	16.7 m
Maximum head:	200 dm
Actual impeller diameter:	240 mm
Code for shaft seal:	BQQE
Curve tolerance:	ISO9906:2012 3B2
Pump version:	A
Materials:	
Pump housing:	Cast iron
Pump housing:	EN-GJL-250
Pump housing:	ASTM class 35
Impeller:	Cast iron
Impeller:	EN-GJL-200
Impeller:	ASTM class 30
Material code:	A
Installation:	
Range of ambient temperature:	-20 .. 50 °C
Maximum operating pressure:	16 bar
Max pressure at stated temp:	16 bar / 120 °C
Type of connection:	DIN
Size of connection:	DN 100
Pressure rating for connection:	PN 16
Port-to-port length:	670 mm
Flange size for motor:	FF265
Connect code:	F
Liquid:	
Pumped liquid:	Water
Liquid temperature range:	-25 .. 120 °C
Selected liquid temperature:	20 °C
Density:	998.2 kg/m³
Electrical data:	
Motor type:	132MH
IE Efficiency class:	IE5
Rated power - P2:	7.5 kW
Mains frequency:	50 Hz
Rated voltage:	3 x 380-500 V
Rated current:	14.1-11.1 A
Cos phi - power factor:	0.93-0.89
Rated speed:	180-2200 rpm
Efficiency:	92.2%
Motor efficiency at full load:	92.2 %
Number of poles:	4
Enclosure class (IEC 34-5):	IP55
Insulation class (IEC 85):	F
Built-in motor protection:	ELEC
Motor No:	98971268
Controls:	
Control panel:	HMI300 - Advanced
Function Module:	FM300 - Advanced
Frequency converter:	Built-in
Others:	
Minimum efficiency index, MEI ≥:	0.45
Net weight:	423 kg
Gross weight:	532 kg
Shipping volume:	1.53 m³
Config. file no:	99139893

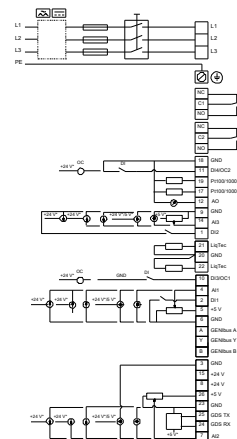
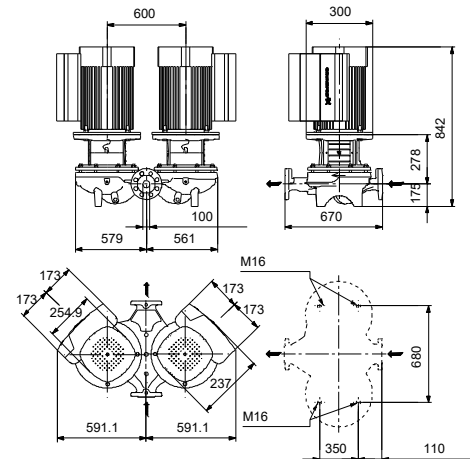
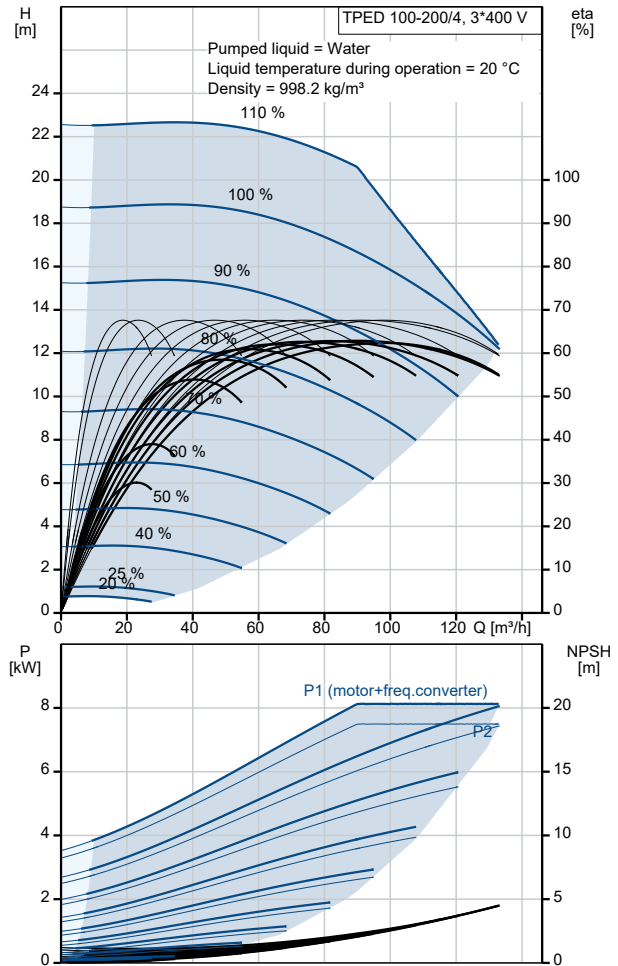

Description	Value
Country of origin:	HU
Custom tariff no.:	84137065

On request TPED 100-200/4 S-A-F-A-BQQE-MDA 50 Hz

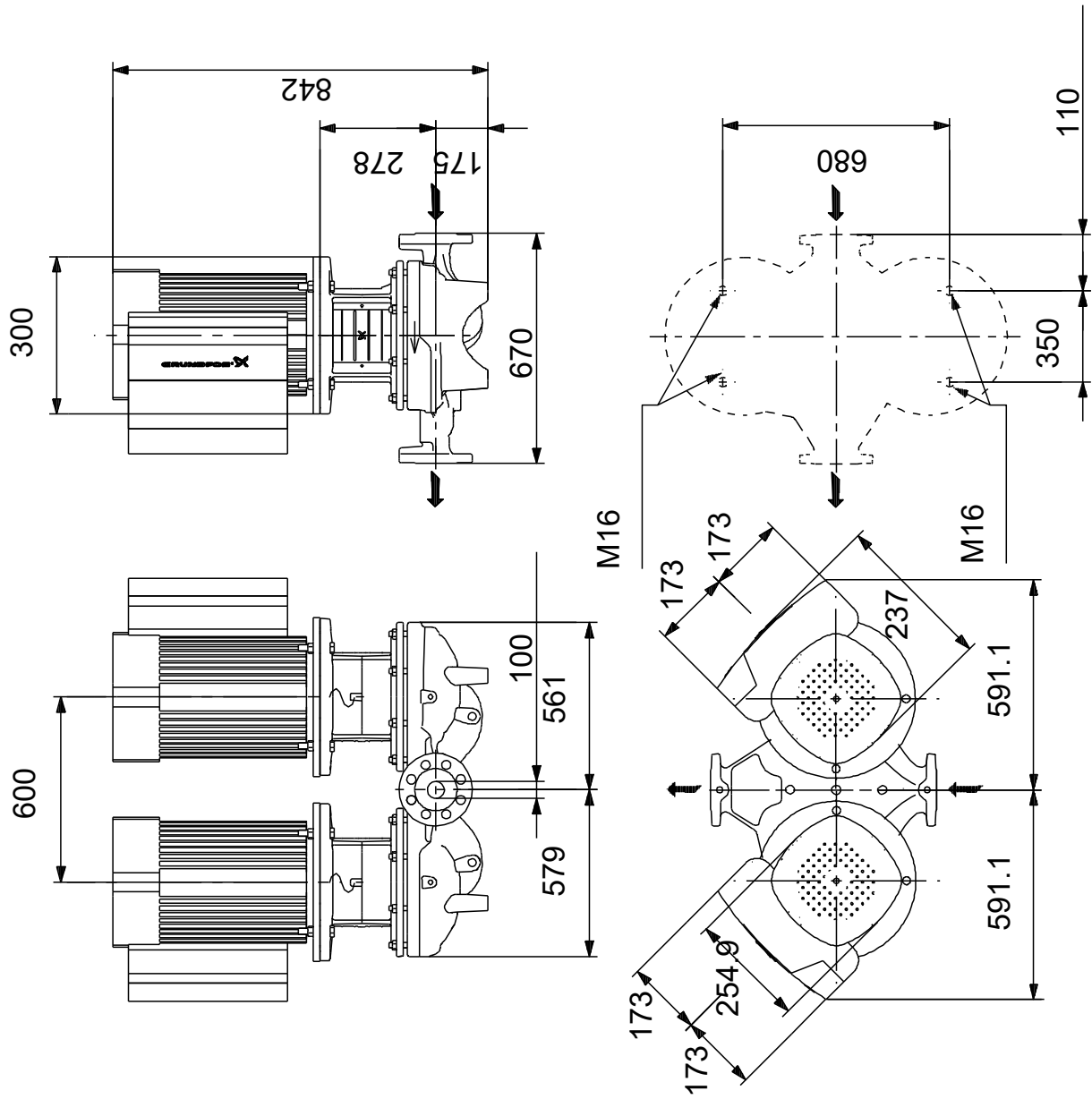

Note! All units are in [mm] unless others are stated.
 Disclaimer: This simplified dimensional drawing does not show all details.

