

Qty.	Description
1	<b>TPED 100-130/4 A-F-A-BQQE-KDA</b>
	
	<p><b>Note! Product picture may differ from actual product</b></p>
	<p>Product No.: On request</p>
	<p>Single-stage, close-coupled, volute twin-head pump with in-line suction and discharge ports of identical diameter. The twin-head pump is designed with two parallel power-heads.</p>
	<p>The pump is of the top-pull-out design, i.e. the power head (motor, pump head and impeller) can be removed for maintenance or service while the pump housing remains in the pipework.</p>
	<p>Each power head is fitted with an unbalanced rubber bellows seal.</p>
	<p>The shaft seal is according to EN 12756. Pipework connection is via PN 16 DIN flanges (EN 1092-2 and ISO 7005-2).</p>
	<p>Each power head is fitted with a fan-cooled, permanent-magnet synchronous motor of identical size. The motor efficiency is classified as IE5 in accordance with IEC 60034-30-2.</p>
	<p>Controls:</p>
	<p>Frequency converter: Built-in</p>
	<p>Liquid:</p>
	<p>Pumped liquid: Water</p>
	<p>Liquid temperature range: -25 .. 120 °C</p>
	<p>Selected liquid temperature: 20 °C</p>
	<p>Density: 998.2 kg/m<sup>3</sup></p>
	<p>Technical:</p>
	<p>Pump speed on which pump data are based: 1455 rpm</p>
	<p>Rated flow: 70.6 m<sup>3</sup>/h</p>
	<p>Rated head: 12 m</p>
	<p>Actual impeller diameter: 200 mm</p>
	<p>Code for shaft seal: BQQE</p>
	<p>Curve tolerance: ISO9906:2012 3B2</p>
	<p>Materials:</p>
	<p>Pump housing: Cast iron EN-GJL-250 ASTM class 35</p>
	<p>Impeller: Cast iron EN-GJL-200 ASTM class 30</p>
	<p>Installation:</p>
	<p>Range of ambient temperature: -20 .. 50 °C</p>
	<p>Maximum operating pressure: 16 bar</p>
	<p>Max pressure at stated temp: 16 bar / 120 °C</p>
	<p>Type of connection: DIN</p>
	<p>Size of connection: DN 100</p>
	<p>Pressure rating for connection: PN 16</p>
	<p>Port-to-port length: 550 mm</p>
	<p>Flange size for motor: FF215</p>
	<p>Electrical data:</p>
	<p>Motor type: 112ME</p>
	<p>IE Efficiency class: IE5</p>
	<p>Rated power - P2: 4 kW</p>
	<p>Mains frequency: 50 Hz</p>
	<p>Rated voltage: 3 x 380-500 V</p>

Qty.	Description
1	<p>Rated current: 7.70-6.00 A  Cos phi - power factor: 0.92-0.87  Rated speed: 180-2200 rpm  Efficiency: 90.3%  Motor efficiency at full load: 90.3 %  Number of poles: 4  Enclosure class (IEC 34-5): IP55  Insulation class (IEC 85): F  Motor No: 98971183</p> <p>Others:  Minimum efficiency index, MEI ≥: 0.70  Net weight: 253 kg  Gross weight: 284 kg  Shipping volume: 1.14 m<sup>3</sup>  Country of origin: HU  Custom tariff no.: 84137065</p>

Description	Value
<b>General information:</b>	
Product name:	TPED 100-130/4 A-F-A-BQQE-KDA
Product No:	On request
EAN number:	On request
<b>Technical:</b>	
Pump speed on which pump data are based:	1455 rpm
Rated flow:	70.6 m <sup>3</sup> /h
Rated head:	12 m
Maximum head:	130 dm
Actual impeller diameter:	200 mm
Code for shaft seal:	BQQE
Curve tolerance:	ISO9906:2012 3B2
Pump version:	A
<b>Materials:</b>	
Pump housing:	Cast iron
Pump housing:	EN-GJL-250
Pump housing:	ASTM class 35
Impeller:	Cast iron
Impeller:	EN-GJL-200
Impeller:	ASTM class 30
Material code:	A
<b>Installation:</b>	
Range of ambient temperature:	-20 .. 50 °C
Maximum operating pressure:	16 bar
Max pressure at stated temp:	16 bar / 120 °C
Type of connection:	DIN
Size of connection:	DN 100
Pressure rating for connection:	PN 16
Port-to-port length:	550 mm
Flange size for motor:	FF215
Connect code:	F
<b>Liquid:</b>	
Pumped liquid:	Water
Liquid temperature range:	-25 .. 120 °C
Selected liquid temperature:	20 °C
Density:	998.2 kg/m <sup>3</sup>
<b>Electrical data:</b>	
Motor type:	112ME
IE Efficiency class:	IE5
Rated power - P2:	4 kW
Mains frequency:	50 Hz
Rated voltage:	3 x 380-500 V
Rated current:	7.70-6.00 A
Cos phi - power factor:	0.92-0.87
Rated speed:	180-2200 rpm
Efficiency:	90.3%
Motor efficiency at full load:	90.3 %
Number of poles:	4
Enclosure class (IEC 34-5):	IP55
Insulation class (IEC 85):	F
Built-in motor protection:	ELEC
Motor No:	98971183
<b>Controls:</b>	
Control panel:	HMI200 - Standard
Function Module:	FM300 - Advanced
Frequency converter:	Built-in
<b>Others:</b>	
Minimum efficiency index, MEI ≥:	0.70
Net weight:	253 kg
Gross weight:	284 kg
Shipping volume:	1.14 m <sup>3</sup>
Config. file no:	99100731

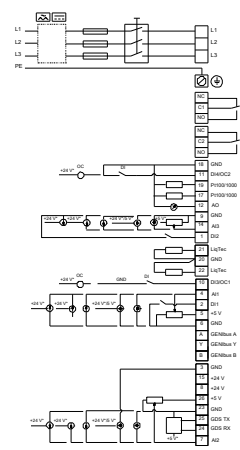
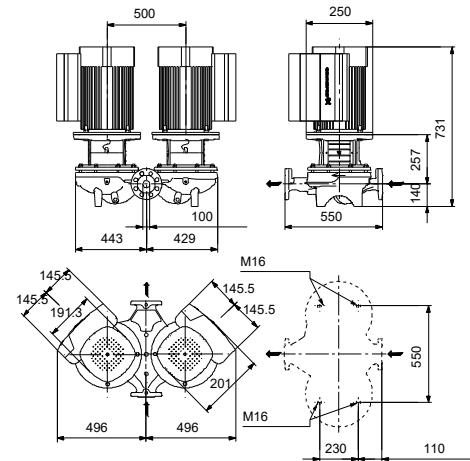
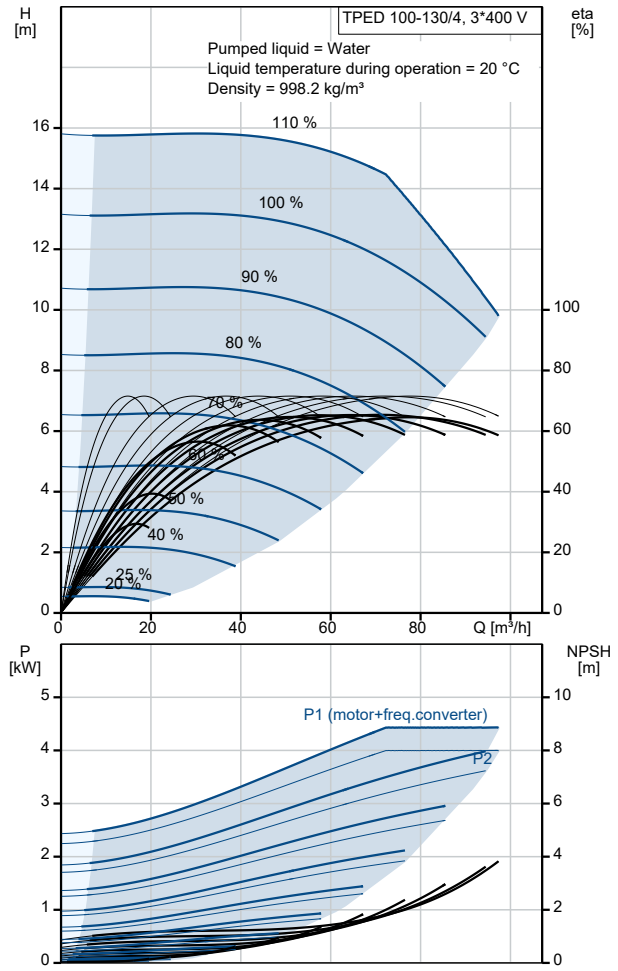

Description	Value
Country of origin:	HU
Custom tariff no.:	84137065

**On request TPED 100-130/4 A-F-A-BQQE-KDA 50 Hz**

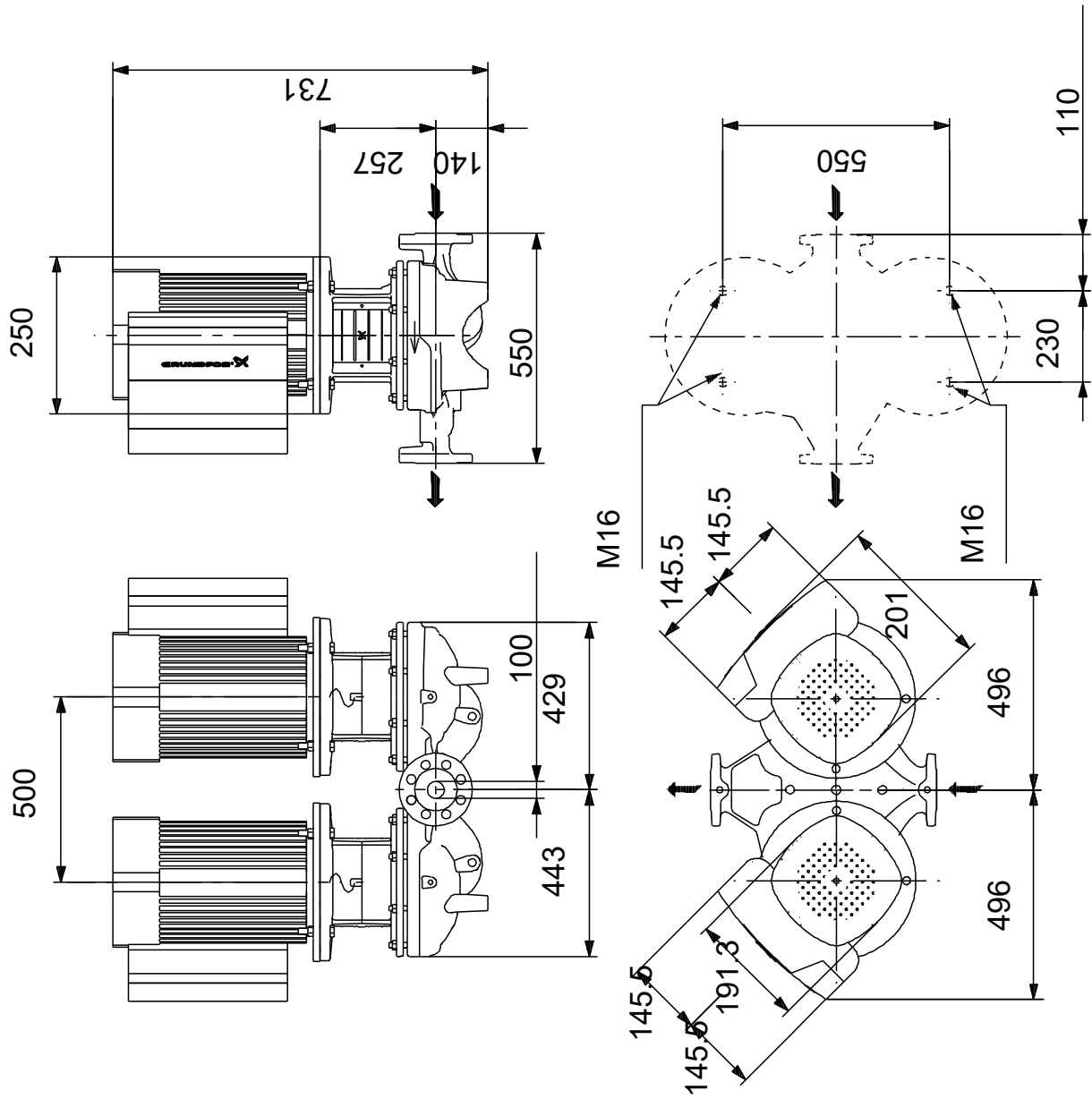

Note! All units are in [mm] unless others are stated.  
 Disclaimer: This simplified dimensional drawing does not show all details.

