

**Qty. Description**1 **NBE 80-250/225 AAF2AESBQQELWA**

**Note! Product picture may differ from actual product**

Product No.: [99101771](#)

Non-self-priming, single-stage, centrifugal volute pump designed according to ISO 5199 with dimensions and rated performance according to EN 733 (10 bar).

Flanges are PN 16 with dimensions according to EN 1092-2. The pump has an axial suction port, radial discharge port, horizontal shaft and a back pull-out design enabling removal of the motor, motor stool, cover and impeller without disturbing the pump housing or pipework.

The unbalanced rubber bellows seal is according to DIN EN 12756.

The pump is close-coupled to a fan-cooled, permanent-magnet synchronous motor.

The motor includes a frequency converter and PI controller in the motor terminal box. This enables continuously variable control of the motor speed, which again enables adaptation of the performance to a given requirement.

The product's minimum efficiency index (MEI) is greater or equal to 0.70. This is by the Commission Regulation (EU) considered as an indicative benchmark for best-performing water pump available on the market as from 1 January 2013.

An external sensor can be connected if controlled pump operation is required for flow, differential pressure or temperature control.

The operating panel on the motor terminal box features a four-inch TFT display, push-buttons and the Grundfos Eye indicator.

The display gives an intuitive and user-friendly interface to all functions.

The push-buttons are used to navigate through the menu structure to access pump and performance data on site and enable setting of required setpoint as well as setting of pump to "Min." or "Max." operation or to "Stop".

The Grundfos Eye indicator on the operating panel provides visual indication of pump status:

- "Power on": Motor is running (rotating green indicator lights) or not running (permanently green indicator lights)
- "Warning": Motor is still running (rotating yellow indicator lights) or has stopped (permanently yellow indicator lights)
- "Alarm": Motor has stopped (flashing red indicator lights).

Communication with the pump is also possible by means of Grundfos GO Remote (accessory). The remote control enables further settings as well as reading out of a number of parameters such as "Actual value", "Speed", "Power input" and total "Power consumption".

The back pull-out design means that the pump can be serviced by a single person without disturbing the pump housing or pipes.

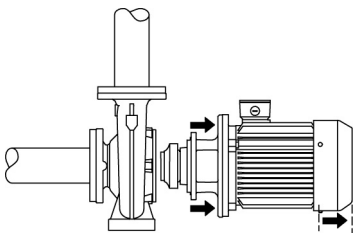

Cast-iron parts have an epoxy-based coating made in a cathodic electro-deposition (CED) process. CED is a high-quality dip-painting process where an electrical field around the products ensures deposition of paint particles as a thin, well-controlled layer on the surface.

## Pump

Motor stool and pump cover are made of cast iron (EN-GJL-250). Coupling guards are fitted to the motor stool.

The pump is fitted with an unbalanced rubber bellows seal with torque transmission across the spring and around the bellows. Due to the bellows, the seal does not wear the shaft, and the axial movement is not prevented by deposits on the shaft.

Seal faces:

- Rotating seal ring material: silicon carbide (SiC)
- Stationary seat material: silicon carbide (SiC)

Qty.	Description																																								
1	<p>This material pairing is used where higher corrosion resistance is required. The high hardness of this material pairing offers good resistance against abrasive particles.</p> <p>Secondary seal material: EPDM (ethylene-propylene rubber)  EPDM has excellent resistance to hot water. EPDM is not suitable for mineral oils.  The pump housing has feet.</p> <p><b>Motor</b></p> <p>The motor is a totally enclosed, fan-cooled motor with principal dimensions to IEC and DIN standards. Electrical tolerances comply with IEC 60034.</p> <p>The motor efficiency is classified as IE5 in accordance with IEC 60034-30-2.</p> <p>The motor requires no external motor protection. The motor control unit incorporates protection against slow- and quick-rising temperatures, e.g. constant overload and stalled conditions.</p> <p>The terminal box holds terminals for these connections:</p> <ul style="list-style-type: none"> <li>- one dedicated digital input</li> <li>- two analog inputs, 0(4)-20 mA, 0-5 V, 0-10 V, 0.5 - 3.5 V</li> <li>- 5 V voltage supply to potentiometer and sensor</li> <li>- one configurable digital input or open-collector output</li> <li>- Grundfos Digital Sensor input and output</li> <li>- 24 V voltage supply for sensors</li> <li>- two signal-relay outputs (potential-free contacts)</li> <li>- GENIbus connection</li> <li>- interface for Grundfos CIM fieldbus module.</li> </ul> <p><b>Further product details</b></p> <p>Cast-iron parts have an epoxy-based coating made in a cathodic electro-deposition (CED) process. CED is a high-quality dip-painting process where an electrical field around the products ensures deposition of paint particles as a thin, well-controlled layer on the surface.</p> <p><b>Technical data</b></p> <p>Controls:</p> <table data-bbox="196 1149 638 1209"> <tr> <td>Frequency converter:</td> <td>Built-in</td> </tr> <tr> <td>Pressure sensor:</td> <td>N</td> </tr> </table> <p>Liquid:</p> <table data-bbox="196 1265 702 1388"> <tr> <td>Pumped liquid:</td> <td>Water</td> </tr> <tr> <td>Liquid temperature range:</td> <td>-25 .. 120 °C</td> </tr> <tr> <td>Selected liquid temperature:</td> <td>20 °C</td> </tr> <tr> <td>Density:</td> <td>998.2 kg/m<sup>3</sup></td> </tr> </table> <p>Technical:</p> <table data-bbox="196 1444 813 1713"> <tr> <td>Pump speed on which pump data are based:</td> <td>1450 rpm</td> </tr> <tr> <td>Rated flow:</td> <td>91.3 m<sup>3</sup>/h</td> </tr> <tr> <td>Rated head:</td> <td>15.3 m</td> </tr> <tr> <td>Actual impeller diameter:</td> <td>225 mm</td> </tr> <tr> <td>Nominal impeller diameter:</td> <td>250</td> </tr> <tr> <td>Shaft seal arrangement:</td> <td>Single</td> </tr> <tr> <td>Code for shaft seal:</td> <td>BQQE</td> </tr> <tr> <td>Curve tolerance:</td> <td>ISO9906:2012 3B2</td> </tr> <tr> <td>Bearing design:</td> <td>Standard</td> </tr> </table> <p>Materials:</p> <table data-bbox="196 1769 734 2094"> <tr> <td>Pump housing:</td> <td>Cast iron EN-GJL-250 ASTM class 35</td> </tr> <tr> <td>Wear ring:</td> <td>Brass</td> </tr> <tr> <td>Impeller:</td> <td>Cast iron EN-GJL-200 ASTM class 30</td> </tr> <tr> <td>Internal pump house coating:</td> <td>CED</td> </tr> <tr> <td>Shaft:</td> <td>Stainless steel EN 1.4301 AISI 304</td> </tr> </table>	Frequency converter:	Built-in	Pressure sensor:	N	Pumped liquid:	Water	Liquid temperature range:	-25 .. 120 °C	Selected liquid temperature:	20 °C	Density:	998.2 kg/m <sup>3</sup>	Pump speed on which pump data are based:	1450 rpm	Rated flow:	91.3 m <sup>3</sup> /h	Rated head:	15.3 m	Actual impeller diameter:	225 mm	Nominal impeller diameter:	250	Shaft seal arrangement:	Single	Code for shaft seal:	BQQE	Curve tolerance:	ISO9906:2012 3B2	Bearing design:	Standard	Pump housing:	Cast iron EN-GJL-250 ASTM class 35	Wear ring:	Brass	Impeller:	Cast iron EN-GJL-200 ASTM class 30	Internal pump house coating:	CED	Shaft:	Stainless steel EN 1.4301 AISI 304
Frequency converter:	Built-in																																								
Pressure sensor:	N																																								
Pumped liquid:	Water																																								
Liquid temperature range:	-25 .. 120 °C																																								
Selected liquid temperature:	20 °C																																								
Density:	998.2 kg/m <sup>3</sup>																																								
Pump speed on which pump data are based:	1450 rpm																																								
Rated flow:	91.3 m <sup>3</sup> /h																																								
Rated head:	15.3 m																																								
Actual impeller diameter:	225 mm																																								
Nominal impeller diameter:	250																																								
Shaft seal arrangement:	Single																																								
Code for shaft seal:	BQQE																																								
Curve tolerance:	ISO9906:2012 3B2																																								
Bearing design:	Standard																																								
Pump housing:	Cast iron EN-GJL-250 ASTM class 35																																								
Wear ring:	Brass																																								
Impeller:	Cast iron EN-GJL-200 ASTM class 30																																								
Internal pump house coating:	CED																																								
Shaft:	Stainless steel EN 1.4301 AISI 304																																								

Qty.	Description
1	<p>Installation:</p> <p>Range of ambient temperature: -20 .. 50 °C</p> <p>Maximum operating pressure: 16 bar</p> <p>Pipe connection standard: EN 1092-2</p> <p>Size of inlet connection: DN 100</p> <p>Size of outlet connection: DN 80</p> <p>Pressure rating for connection: PN 16</p> <p>Bearing lubrication: Grease</p> <p>Pump housing with feet: Yes</p> <p>Support block (Yes/No): N</p> <p>Electrical data:</p> <p>IE Efficiency class: IE5</p> <p>Rated power - P2: 5.5 kW</p> <p>Mains frequency: 50 Hz</p> <p>Rated voltage: 3 x 380-500 V</p> <p>Rated current: 10.5-8.40 A</p> <p>Cos phi - power factor: 0.92-0.88</p> <p>Rated speed: 180-2200 rpm</p> <p>Efficiency: 91.9%</p> <p>Motor efficiency at full load: 91.9 %</p> <p>Number of poles: 4</p> <p>Enclosure class (IEC 34-5): IP55</p> <p>Insulation class (IEC 85): F</p> <p>Motor No: 98971267</p> <p>Bearing insulation type N-end: STEEL BEARING</p> <p>Others:</p> <p>Minimum efficiency index, MEI ≥: 0.70</p> <p>Net weight: 136 kg</p> <p>Gross weight: 157 kg</p> <p>Shipping volume: 0.509 m<sup>3</sup></p> <p>Danish VVS No.: 386104251</p> <p>Country of origin: HU</p> <p>Custom tariff no.: 84137051</p>

# 99101771 NBE 80-250/225 AAF2AESBQQELWA 50 Hz

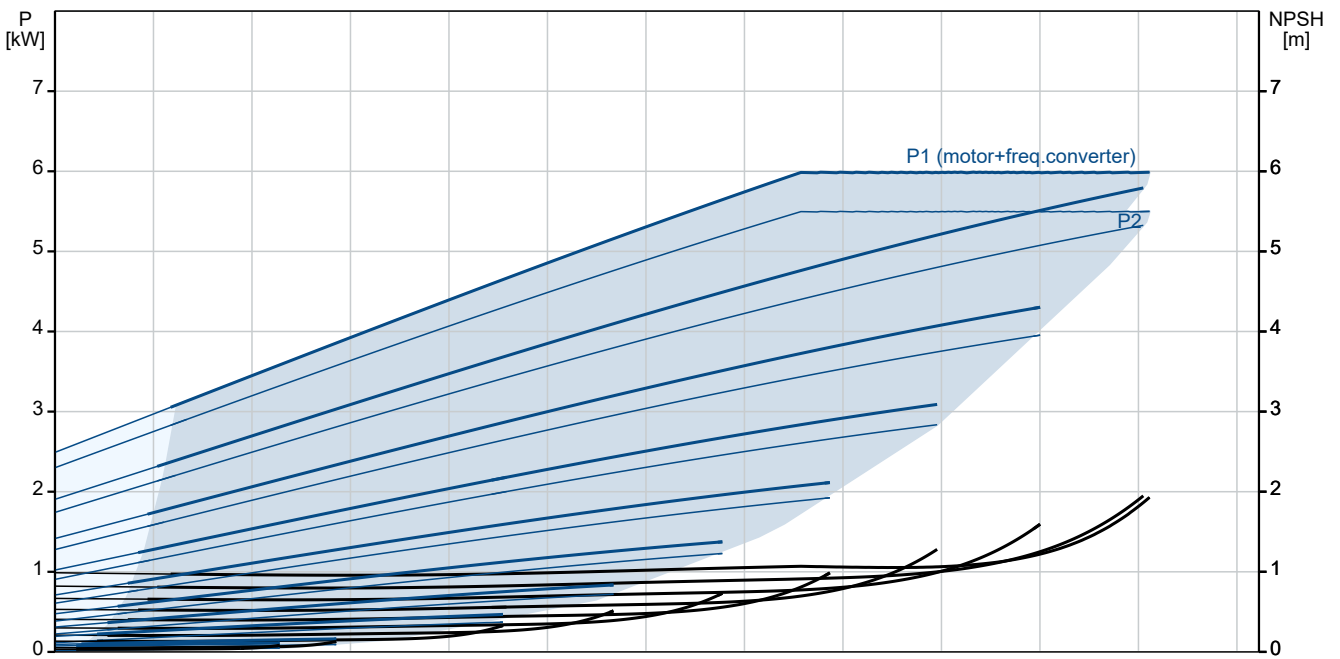
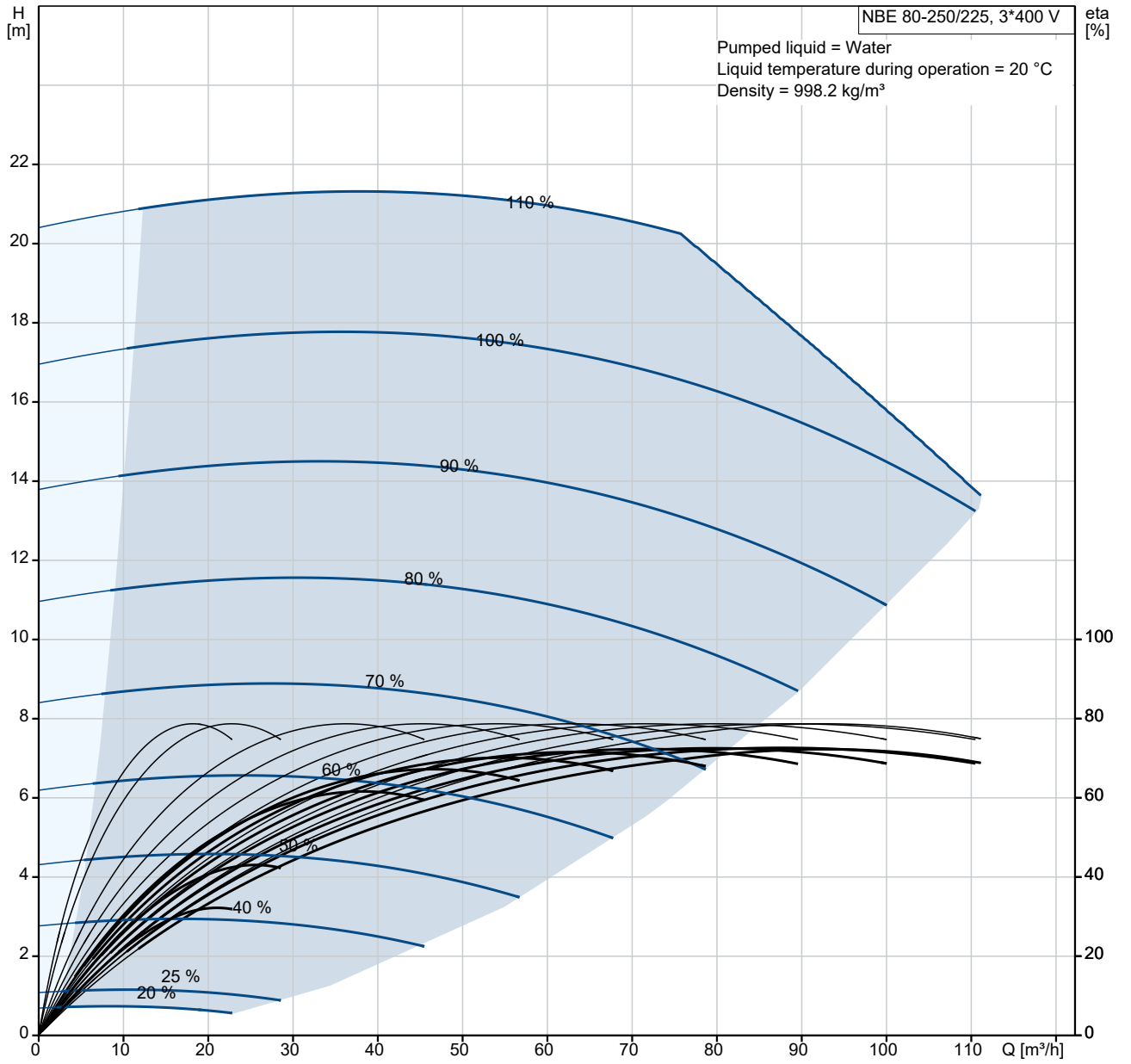

Description	Value
<b>General information:</b>	
Product name:	NBE 80-250/225 AAF2AESBQQELWA
Product No:	99101771
EAN number:	5712606788316
<b>Technical:</b>	
Pump speed on which pump data are based:	1450 rpm
Rated flow:	91.3 m <sup>3</sup> /h
Rated head:	15.3 m
Actual impeller diameter:	225 mm
Nominal impeller diameter:	250
Shaft seal arrangement:	Single
Shaft diameter:	32 mm
Code for shaft seal:	BQQE
Curve tolerance:	ISO9906:2012 3B2
Pump version:	A
Bearing design:	Standard
<b>Materials:</b>	
Pump housing:	Cast iron
Pump housing:	EN-GJL-250
Pump housing:	ASTM class 35
Wear ring:	Brass
Impeller:	Cast iron
Impeller:	EN-GJL-200
Impeller:	ASTM class 30
Internal pump house coating:	CED
Material code:	A
Code for rubber:	E
Shaft:	Stainless steel
Shaft:	EN 1.4301
Shaft:	AISI 304
<b>Installation:</b>	
Range of ambient temperature:	-20 .. 50 °C
Maximum operating pressure:	16 bar
Pipe connection standard:	EN 1092-2
Size of inlet connection:	DN 100
Size of outlet connection:	DN 80
Pressure rating for connection:	PN 16
Bearing lubrication:	Grease
Pump housing with feet:	Yes
Support block (Yes/No):	N
Connect code:	F2
<b>Liquid:</b>	
Pumped liquid:	Water
Liquid temperature range:	-25 .. 120 °C
Selected liquid temperature:	20 °C
Density:	998.2 kg/m <sup>3</sup>
<b>Electrical data:</b>	
IE Efficiency class:	IE5
Rated power - P2:	5.5 kW
Mains frequency:	50 Hz
Rated voltage:	3 x 380-500 V
Rated current:	10.5-8.40 A
Cos phi - power factor:	0.92-0.88
Rated speed:	180-2200 rpm
Efficiency:	91.9%
Motor efficiency at full load:	91.9%
Number of poles:	4
Enclosure class (IEC 34-5):	IP55
Insulation class (IEC 85):	F
Built-in motor protection:	ELEC
Motor No:	98971267
Mount. design. acc. IEC 34-7:	IM V1/B5

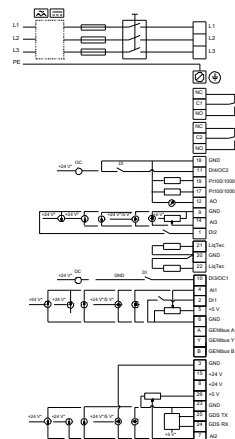
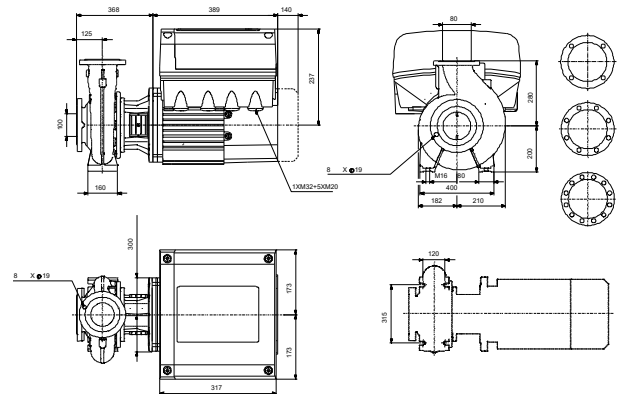
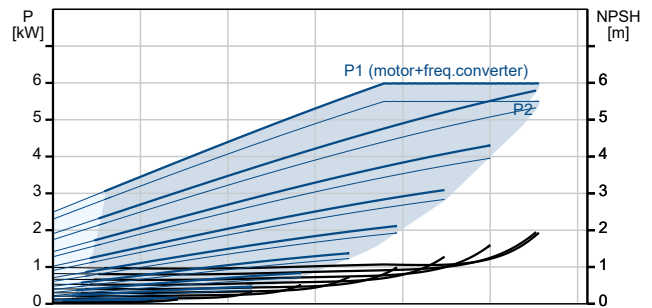
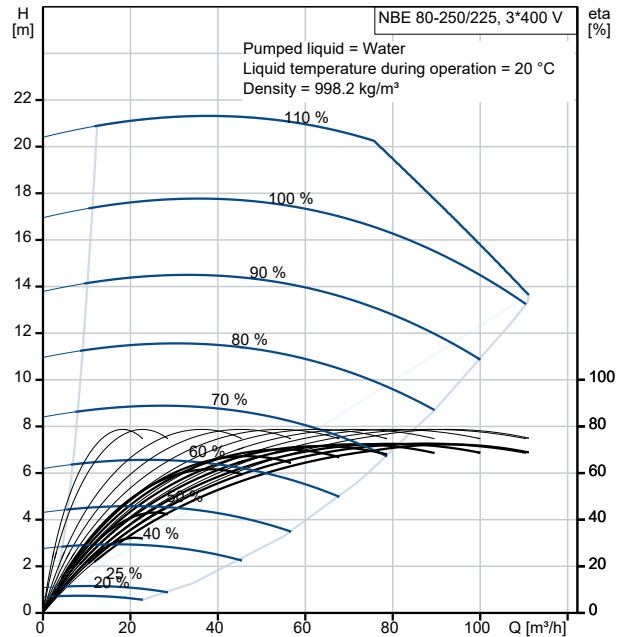

Description	Value
Bearing insulation type N-end:	STEEL BEARING
<b>Controls:</b>	
Control panel:	HMI300 - Advanced
Function Module:	FM300 - Advanced
Frequency converter:	Built-in
Pressure sensor:	N
<b>Others:</b>	
Minimum efficiency index, MEI ≥:	0.70
Net weight:	136 kg
Gross weight:	157 kg
Shipping volume:	0.509 m <sup>3</sup>
Danish VVS No.:	386104251
Country of origin:	HU
Custom tariff no.:	84137051

# 99101771 NBE 80-250/225 AAF2AESBQQELWA 50 Hz

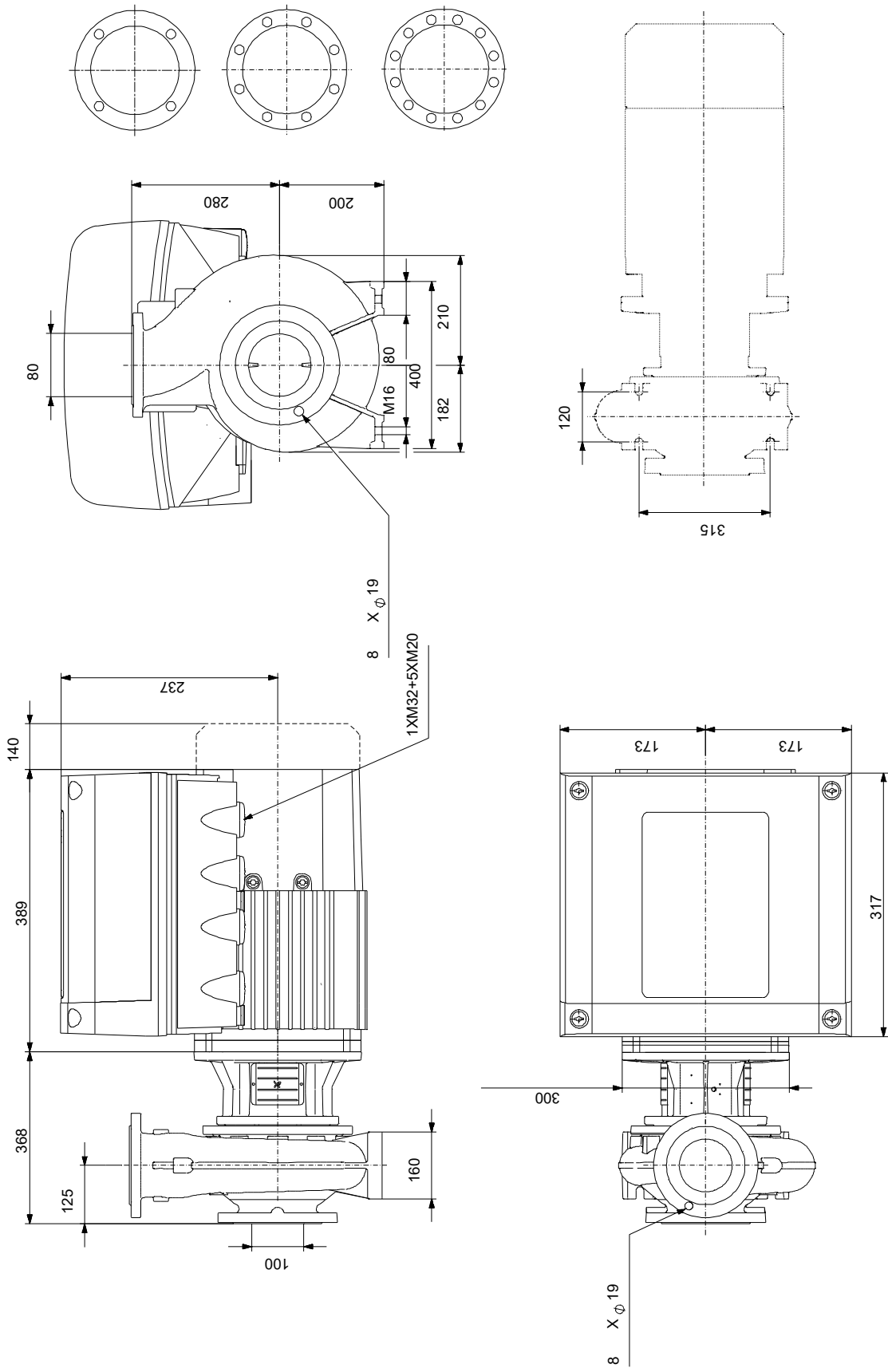

Note! All units are in [mm] unless others are stated.  
 Disclaimer: This simplified dimensional drawing does not show all details.

# 99101771 NBE 80-250/225 AAF2AESBQQELWA 50 Hz

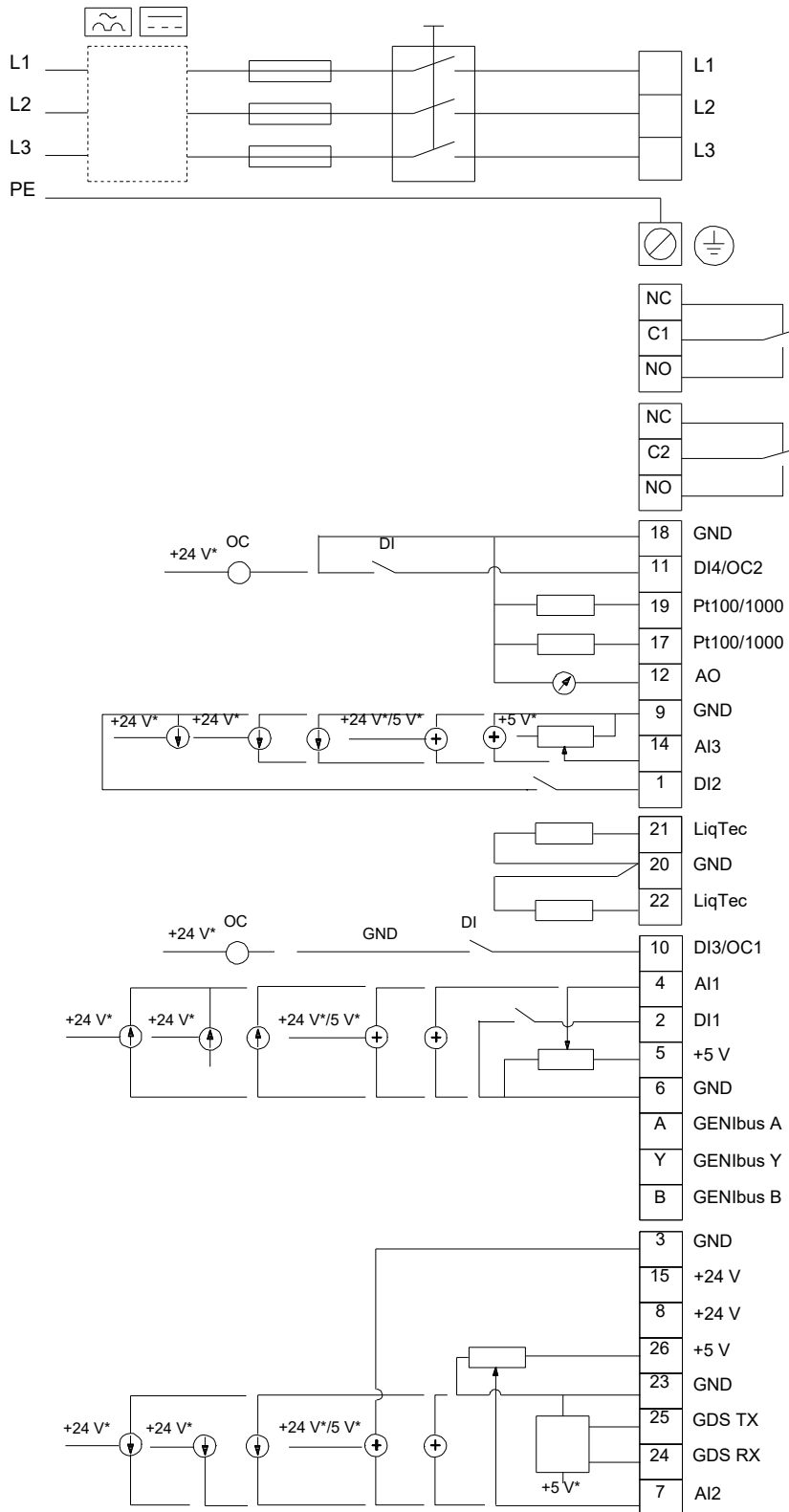

Note! All units are in [mm] unless others are stated.



**Order Data:**

<b>Position</b>	<b>Your pos.</b>	<b>Product name</b>	<b>Amount</b>	<b>Product No</b>	<b>Total</b>
		NBE 80-250/225	1	99101771	Price on request