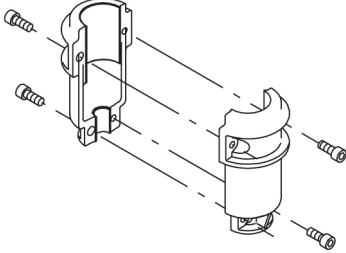
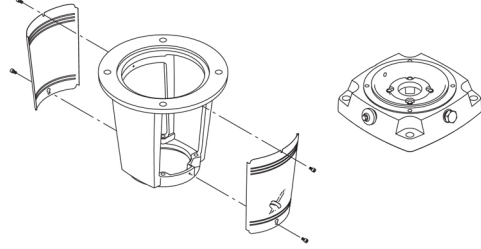
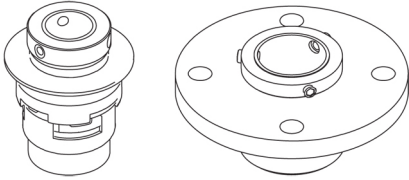
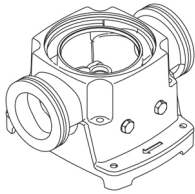

Qty.	Description
1	<p data-bbox="201 159 507 188"><b>CRE 32-4-2 N-F-A-E-HQQE</b></p>  <p data-bbox="592 506 1062 528" style="text-align: center;"><b>Note! Product picture may differ from actual product</b></p> <p data-bbox="201 539 464 562">Product No.: <a href="#">99071960</a></p> <p data-bbox="201 600 1430 696">Vertical, multistage centrifugal pump with inlet and outlet ports on same the level (inline). The pump head and base are in cast iron – all other wetted parts are in stainless steel. A cartridge shaft seal ensures high reliability, safe handling, and easy access and service. Power transmission is via a rigid split coupling. Pipe connection is via DIN flanges.</p> <p data-bbox="201 741 1126 763">The pump is fitted with a 3-phase, fan-cooled, permanent-magnet, synchronous motor.</p> <p data-bbox="201 770 1015 792">The motor efficiency is classified as IE5 in accordance with IEC 60034-30-2.</p> <p data-bbox="201 799 1394 851">The motor includes a frequency converter and PI controller in the motor terminal box. This enables continuously variable control of the motor speed, which again enables adaptation of the performance to a given requirement.</p> <p data-bbox="201 857 1449 931">An operating panel on the motor terminal box enables setting of required setpoint as well as setting of pump to "Min." or "Max." operation or to "Stop". The Grundfos Eye indicator on the operating panel provides visual indication of pump status:</p> <ul data-bbox="240 943 1458 1088" style="list-style-type: none"> <li>• "Power on": Motor is running (rotating green indicator lights) or not running (permanently green indicator lights)</li> <li>• "Warning": Motor is still running (rotating yellow indicator lights) or has stopped (permanently yellow indicator lights)</li> <li>• "Alarm": Motor has stopped (flashing red indicator lights).</li> </ul> <p data-bbox="201 1093 1422 1167">Communication with the pump is possible by means of Grundfos GO Remote (accessory). The remote control enables further settings as well as reading out of a number of parameters such as "Actual value", "Speed", "Power input" and total "Power consumption".</p> <p data-bbox="201 1173 1437 1225">The terminal box has a number of inputs and outputs enabling the motor to be used in advanced applications where many inputs and outputs are required:</p> <ul data-bbox="240 1236 1434 1615" style="list-style-type: none"> <li>• two dedicated digital inputs</li> <li>• three analog inputs, 0(4)-20 mA, 0-5 V, 0-10 V, 0.5 - 3.5 V; the factory-fitted pressure sensor is connected to one of these inputs</li> <li>• 5 V voltage supply to potentiometer and sensor</li> <li>• one analog output, 0-10 V, 0(4)-20 mA</li> <li>• two configurable digital inputs or open-collector outputs</li> <li>• two Pt100/Pt1000 inputs</li> <li>• LiqTec, dry-running protection sensor input</li> <li>• Grundfos Digital Sensor input and output</li> <li>• 24 V voltage supply for sensors</li> <li>• two signal-relay outputs (potential-free contacts)</li> <li>• GENIbus connection</li> <li>• interface for Grundfos CIM fieldbus module.</li> </ul> <p data-bbox="201 1648 512 1675"><b>Further product details</b></p> <p data-bbox="201 1682 1366 1733">The pump is equipped with a pressure sensor registering pump outlet pressure and enabling controlled pump operation based on constant pressure.</p> <p data-bbox="201 1740 1449 1814">An operating panel on the motor terminal box enables setting of required setpoint as well as setting of pump to "Min." or "Max." operation or to "Stop". The Grundfos Eye indicator on the operating panel provides visual indication of pump status:</p> <ul data-bbox="240 1825 1458 1971" style="list-style-type: none"> <li>• "Power on": Motor is running (rotating green indicator lights) or not running (permanently green indicator lights)</li> <li>• "Warning": Motor is still running (rotating yellow indicator lights) or has stopped (permanently yellow indicator lights)</li> <li>• "Alarm": Motor has stopped (flashing red indicator lights).</li> </ul> <p data-bbox="201 1977 1422 2051">Communication with the pump is possible by means of Grundfos GO Remote (accessory). The remote control enables further settings as well as reading out of a number of parameters such as "Actual value", "Speed", "Power input" and total "Power consumption".</p>

Qty.	Description
1	<p>Steel, cast iron and aluminium components have an epoxy-based coating made in a cathodic electro-deposition (CED) process.</p> <p>CED is a high-quality dip-painting process where an electrical field around the products ensures deposition of paint particles as a thin, well-controlled layer on the surface.</p> <p>An integral part of the process is a pretreatment.</p> <p>The entire process consists of these elements:</p> <ol style="list-style-type: none"> <li>1) Alkaline-based cleaning.</li> <li>2) Zinc phosphating.</li> <li>3) Cathodic electro-deposition.</li> <li>4) Curing to a dry film thickness 18-22 my m.</li> </ol> <p>The colour code for the finished product is NCS 9000/RAL 9005.</p> <p><b>Pump</b></p> <p>A long split coupling connects the pump and motor shaft. It is enclosed in the motor stool by means of two coupling guards. The long coupling makes it possible to replace the shaft seal without removing the motor from the pump.</p>  <p>The motor stool connects the pump head and motor. The pump head has a combined 1/2" priming plug and vent screw.</p>  <p>The pump is fitted with a balanced O-ring seal unit with a rigid torque-transmission system. This seal type is assembled in a cartridge unit which makes replacement safe and easy. Due to the balancing, this seal type is suitable for high-pressure applications. The cartridge construction also protects the pump shaft from possible wear from a dynamic O-ring between pump shaft and shaft seal.</p> <p>Seal faces:</p> <ul style="list-style-type: none"> <li>• Rotating seal ring material: silicon carbide (SiC)</li> <li>• Stationary seat material: silicon carbide (SiC)</li> </ul> <p>This material pairing is used where higher corrosion resistance is required. The high hardness of this material pairing offers good resistance against abrasive particles.</p> <p>Secondary seal material: EPDM (ethylene-propylene rubber)</p> <p>EPDM has excellent resistance to hot water. EPDM is not suitable for mineral oils.</p>  <p>The shaft seal is retained in the pump head by a cover and screws. It can be replaced without removing the motor.</p> <p>The chambers and impellers are made of stainless-steel sheet. The chambers are provided with a PTFE neck ring offering improved sealing and high efficiency. The impellers have smooth surfaces, and the shape of the blades ensure a high efficiency.</p> <p>The base is made of cast iron. Both the inlet and the outlet side of the base have two pressure gauge tappings. The pump is secured to the foundation by four bolts through the base plate. The flanges are fastened to the base by means of locking rings.</p>

**Qty. Description**

1

**Motor**

The motor is a totally enclosed, fan-cooled motor with principal dimensions to IEC and DIN standards. The motor is flange-mounted with free-hole flange (FF).

Motor-mounting designation in accordance with IEC 60034-7: IM B 5 (Code I) / IM 3001 (Code II).

Electrical tolerances comply with IEC 60034.

The motor efficiency is classified as IE5 in accordance with IEC 60034-30-2.

The motor requires no external motor protection. The motor control unit incorporates protection against slow- and quick-rising temperatures, e.g. constant overload and stalled conditions.

**Technical data****Liquid:**

Pumped liquid: Water  
Liquid temperature range: -30 .. 120 °C  
Selected liquid temperature: 20 °C  
Density: 998.2 kg/m<sup>3</sup>

**Technical:**

Pump speed on which pump data are based: 3529 rpm  
Rated flow: 36 m<sup>3</sup>/h  
Rated head: 78.2 m  
Pump orientation: Vertical  
Shaft seal arrangement: Single  
Code for shaft seal: HQQE  
Approvals and markings: CE,EAC,UKCA,SEPRO  
Approvals for drinking water: WRAS,ACS  
Curve tolerance: ISO9906:2012 3B

**Materials:**

Base: Cast iron  
EN 1563 EN-GJS-500-7  
ASTM A536 80-55-06  
Impeller: Stainless steel  
EN 1.4301  
AISI 304

Bearing arrangement: SIC  
Support bearing: Graflon

**Installation:**

t max amb: 50 °C  
Maximum operating pressure: 16 bar  
Max pressure at stated temp: 16 bar / 120 °C  
16 bar / -30 °C

Type of connection: DIN  
Size of inlet connection: DN 65  
Size of outlet connection: DN 65  
Pressure rating for connection: PN 40  
Flange size for motor: FF300

**Electrical data:**

Motor standard: IEC  
Motor type: 160MH  
IE Efficiency class: IE5  
Rated power - P2: 11 kW  
Power (P2) required by pump: 11 kW  
Over/undersize motor: Standard motor size

Qty.	Description																																										
1	<table border="0"> <tr> <td>Mains frequency:</td> <td>50 / 60 Hz</td> </tr> <tr> <td>Rated voltage:</td> <td>3 x 380-500 V</td> </tr> <tr> <td>Rated current:</td> <td>20.3-16.0 A</td> </tr> <tr> <td>Cos phi - power factor:</td> <td>0.93-0.90</td> </tr> <tr> <td>Rated speed:</td> <td>360-4000 rpm</td> </tr> <tr> <td>Efficiency:</td> <td>93.1%</td> </tr> <tr> <td>Motor efficiency at full load:</td> <td>93.1 %</td> </tr> <tr> <td>Enclosure class (IEC 34-5):</td> <td>IP55</td> </tr> <tr> <td>Insulation class (IEC 85):</td> <td>F</td> </tr> <tr> <td>Motor No:</td> <td>98971053</td> </tr> <tr> <td colspan="2">Controls:</td> </tr> <tr> <td>Frequency converter:</td> <td>Built-in</td> </tr> <tr> <td>Pressure sensor:</td> <td>Y</td> </tr> <tr> <td colspan="2">Others:</td> </tr> <tr> <td>Minimum efficiency index, MEI ≥:</td> <td>0.70</td> </tr> <tr> <td>Net weight:</td> <td>132 kg</td> </tr> <tr> <td>Gross weight:</td> <td>165 kg</td> </tr> <tr> <td>Shipping volume:</td> <td>0.495 m<sup>3</sup></td> </tr> <tr> <td>Danish VVS No.:</td> <td>386006181</td> </tr> <tr> <td>Country of origin:</td> <td>GB</td> </tr> <tr> <td>Custom tariff no.:</td> <td>84137075</td> </tr> </table>	Mains frequency:	50 / 60 Hz	Rated voltage:	3 x 380-500 V	Rated current:	20.3-16.0 A	Cos phi - power factor:	0.93-0.90	Rated speed:	360-4000 rpm	Efficiency:	93.1%	Motor efficiency at full load:	93.1 %	Enclosure class (IEC 34-5):	IP55	Insulation class (IEC 85):	F	Motor No:	98971053	Controls:		Frequency converter:	Built-in	Pressure sensor:	Y	Others:		Minimum efficiency index, MEI ≥:	0.70	Net weight:	132 kg	Gross weight:	165 kg	Shipping volume:	0.495 m <sup>3</sup>	Danish VVS No.:	386006181	Country of origin:	GB	Custom tariff no.:	84137075
Mains frequency:	50 / 60 Hz																																										
Rated voltage:	3 x 380-500 V																																										
Rated current:	20.3-16.0 A																																										
Cos phi - power factor:	0.93-0.90																																										
Rated speed:	360-4000 rpm																																										
Efficiency:	93.1%																																										
Motor efficiency at full load:	93.1 %																																										
Enclosure class (IEC 34-5):	IP55																																										
Insulation class (IEC 85):	F																																										
Motor No:	98971053																																										
Controls:																																											
Frequency converter:	Built-in																																										
Pressure sensor:	Y																																										
Others:																																											
Minimum efficiency index, MEI ≥:	0.70																																										
Net weight:	132 kg																																										
Gross weight:	165 kg																																										
Shipping volume:	0.495 m <sup>3</sup>																																										
Danish VVS No.:	386006181																																										
Country of origin:	GB																																										
Custom tariff no.:	84137075																																										

# 99071960 CRE 32-4-2 N-F-A-E-HQQE

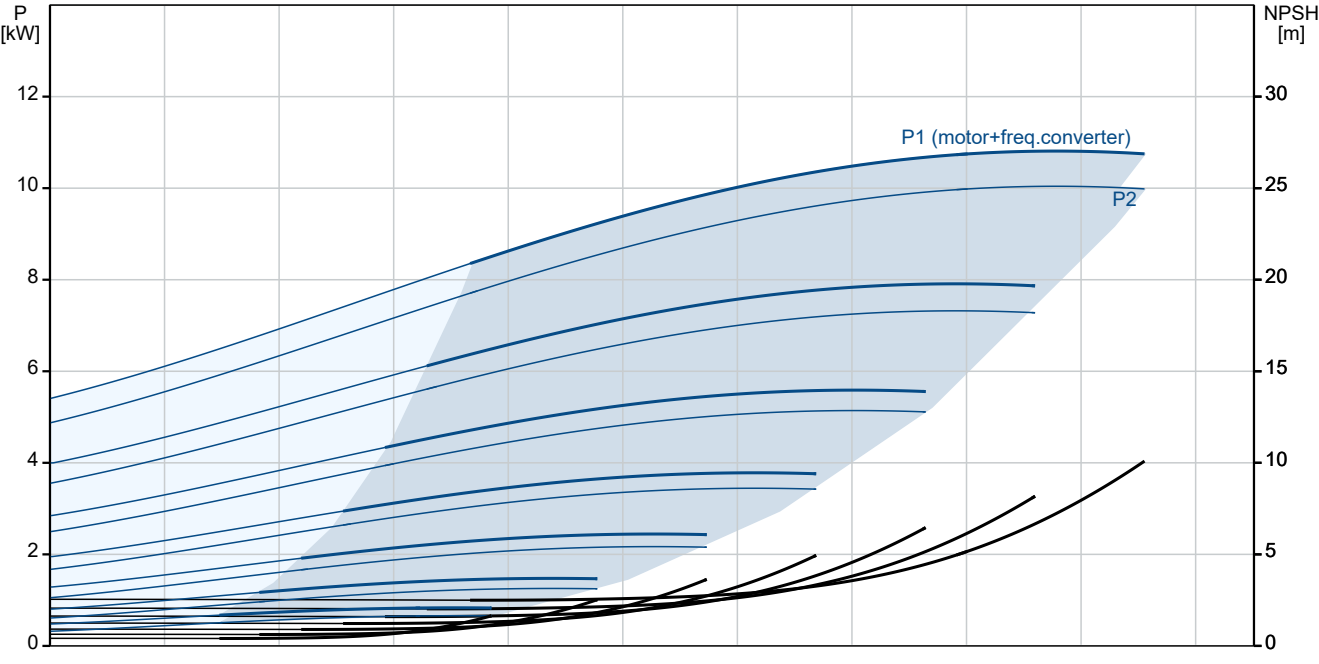
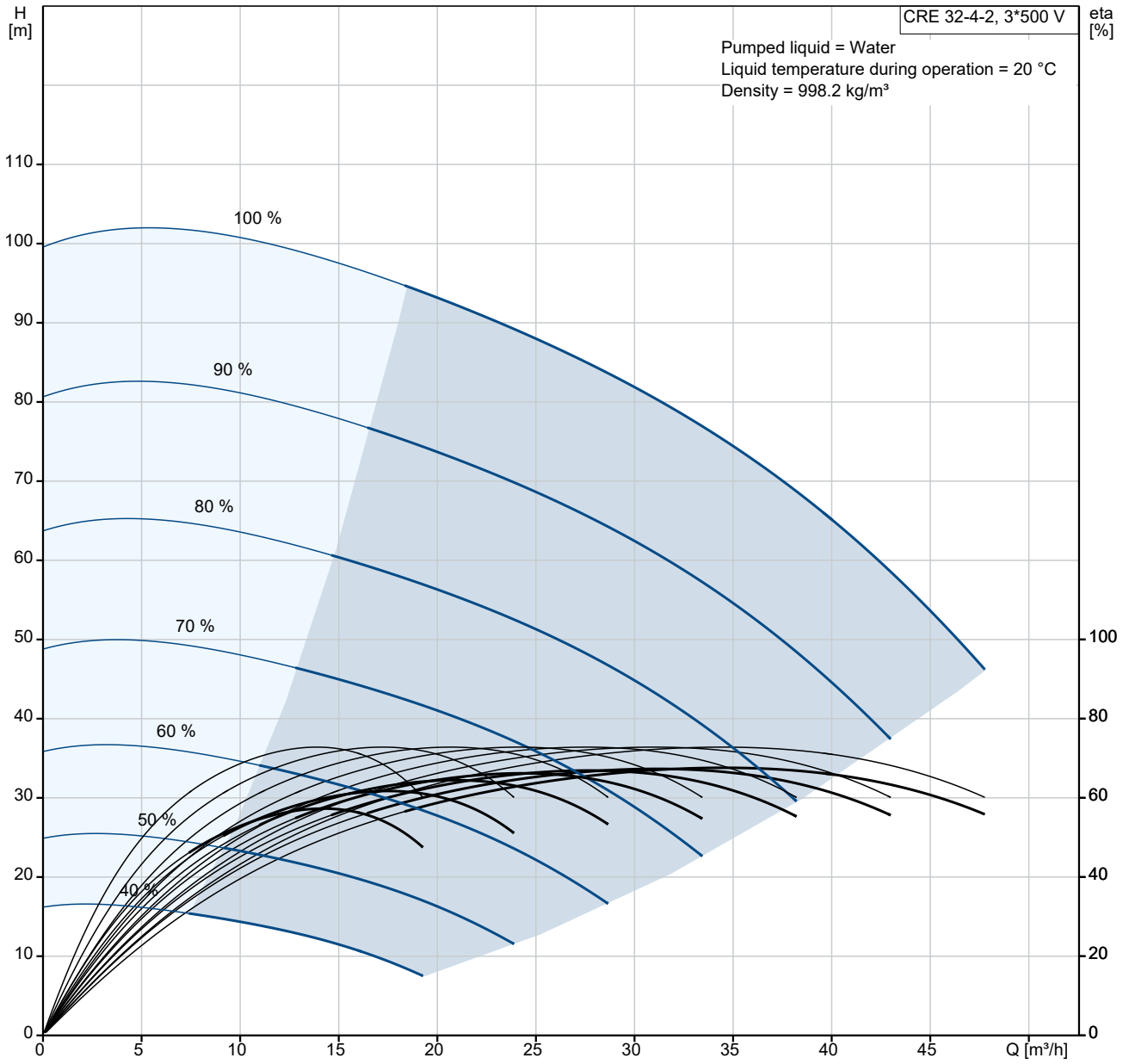

Description	Value
<b>General information:</b>	
Product name:	CRE 32-4-2 N-F-A-E-HQQE
Product No:	99071960
EAN number:	5712606201594
<b>Technical:</b>	
Pump speed on which pump data are based:	3529 rpm
Rated flow:	36 m <sup>3</sup> /h
Rated head:	78.2 m
Maximum head:	101.9 m
Number of stages:	4
Impellers:	4
Number of reduced-diameter impellers:	2
Low NPSH:	N
Pump orientation:	Vertical
Shaft seal arrangement:	Single
Code for shaft seal:	HQQE
Approvals and markings:	CE,EAC,UKCA,SEPRO
Approvals for drinking water:	WRAS,ACS
Curve tolerance:	ISO9906:2012 3B
Pump version:	N
The first model is called A which is followed by model B, C etc.:	B
<b>Materials:</b>	
Base:	Cast iron
Base:	EN 1563 EN-GJS-500-7
Base:	ASTM A536 80-55-06
Impeller:	Stainless steel
Impeller:	EN 1.4301
Impeller:	AISI 304
Material code:	A
Code for rubber:	E
Bearing arrangement:	SIC
Support bearing:	Graflon
<b>Installation:</b>	
t max amb:	50 °C
Maximum operating pressure:	16 bar
Max pressure at stated temp:	16 bar / 120 °C
Max pressure at stated temp:	16 bar / -30 °C
Type of connection:	DIN
Size of inlet connection:	DN 65
Size of outlet connection:	DN 65
Pressure rating for connection:	PN 40
Flange size for motor:	FF300
Connect code:	F
<b>Liquid:</b>	
Pumped liquid:	Water
Liquid temperature range:	-30 .. 120 °C
Selected liquid temperature:	20 °C
Density:	998.2 kg/m <sup>3</sup>
<b>Electrical data:</b>	
Motor standard:	IEC
Motor type:	160MH
IE Efficiency class:	IE5
Rated power - P2:	11 kW
Power (P2) required by pump:	11 kW
Over/undersize motor:	Standard motor size
Mains frequency:	50 / 60 Hz
Rated voltage:	3 x 380-500 V
Rated current:	20.3-16.0 A
Cos phi - power factor:	0.93-0.90
Rated speed:	360-4000 rpm
Efficiency:	93.1%
Motor efficiency at full load:	93.1%

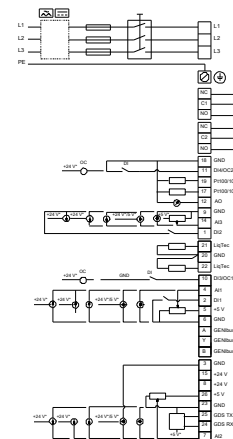
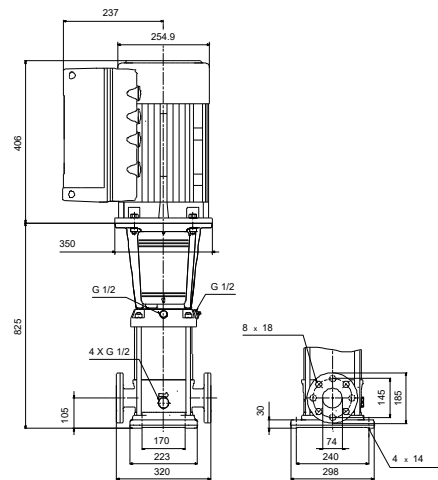
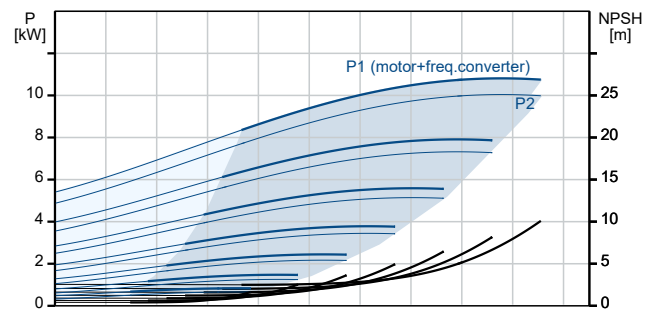
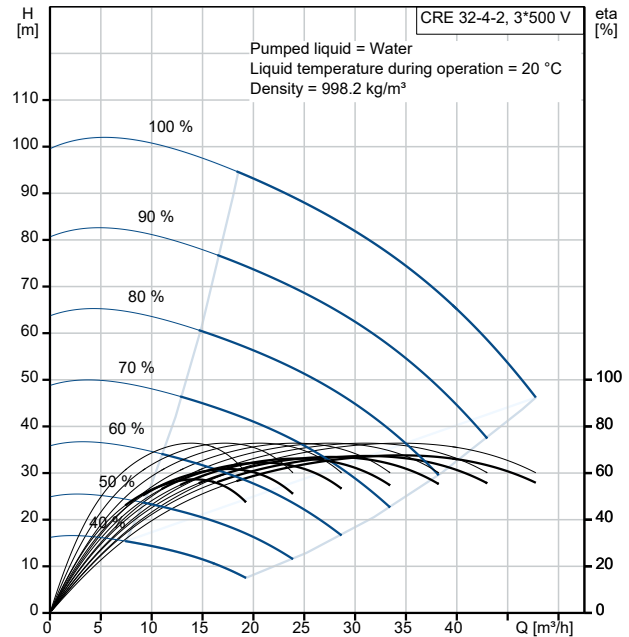

Description	Value
Enclosure class (IEC 34-5):	IP55
Insulation class (IEC 85):	F
Built-in motor protection:	ELEC
Motor No:	98971053
<b>Controls:</b>	
Control panel:	Standard
Function Module:	FM300 - Advanced
Frequency converter:	Built-in
Pressure sensor:	Y
<b>Others:</b>	
Minimum efficiency index, MEI ≥:	0.70
Net weight:	132 kg
Gross weight:	165 kg
Shipping volume:	0.495 m <sup>3</sup>
Config. file no:	99059300
Danish VVS No.:	386006181
Country of origin:	GB
Custom tariff no.:	84137075

# 99071960 CRE 32-4-2 N-F-A-E-HQQE

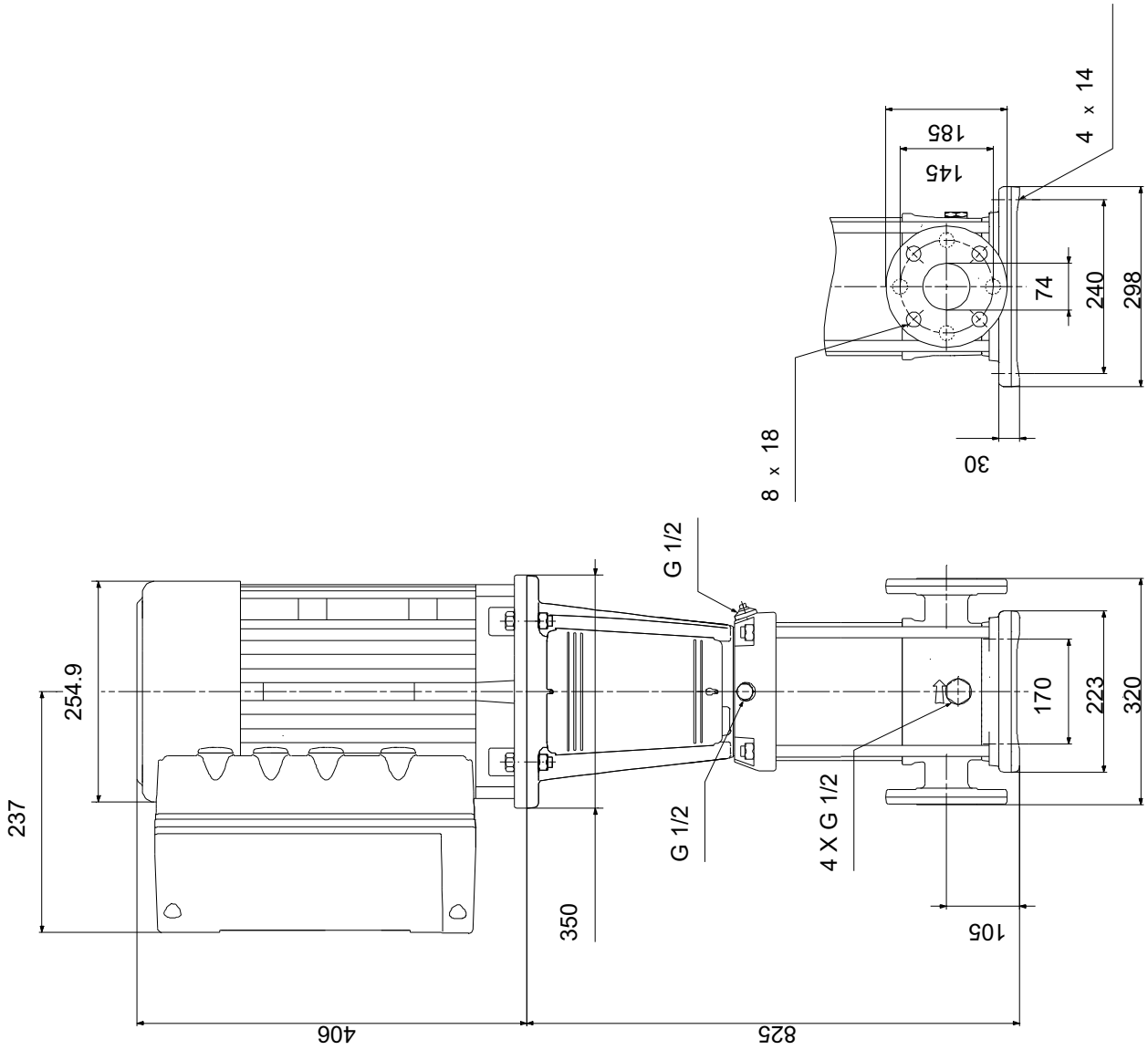

Note! All units are in [mm] unless others are stated.  
Disclaimer: This simplified dimensional drawing does not show all details.



# 99071960 CRE 32-4-2 N-F-A-E-HQQE

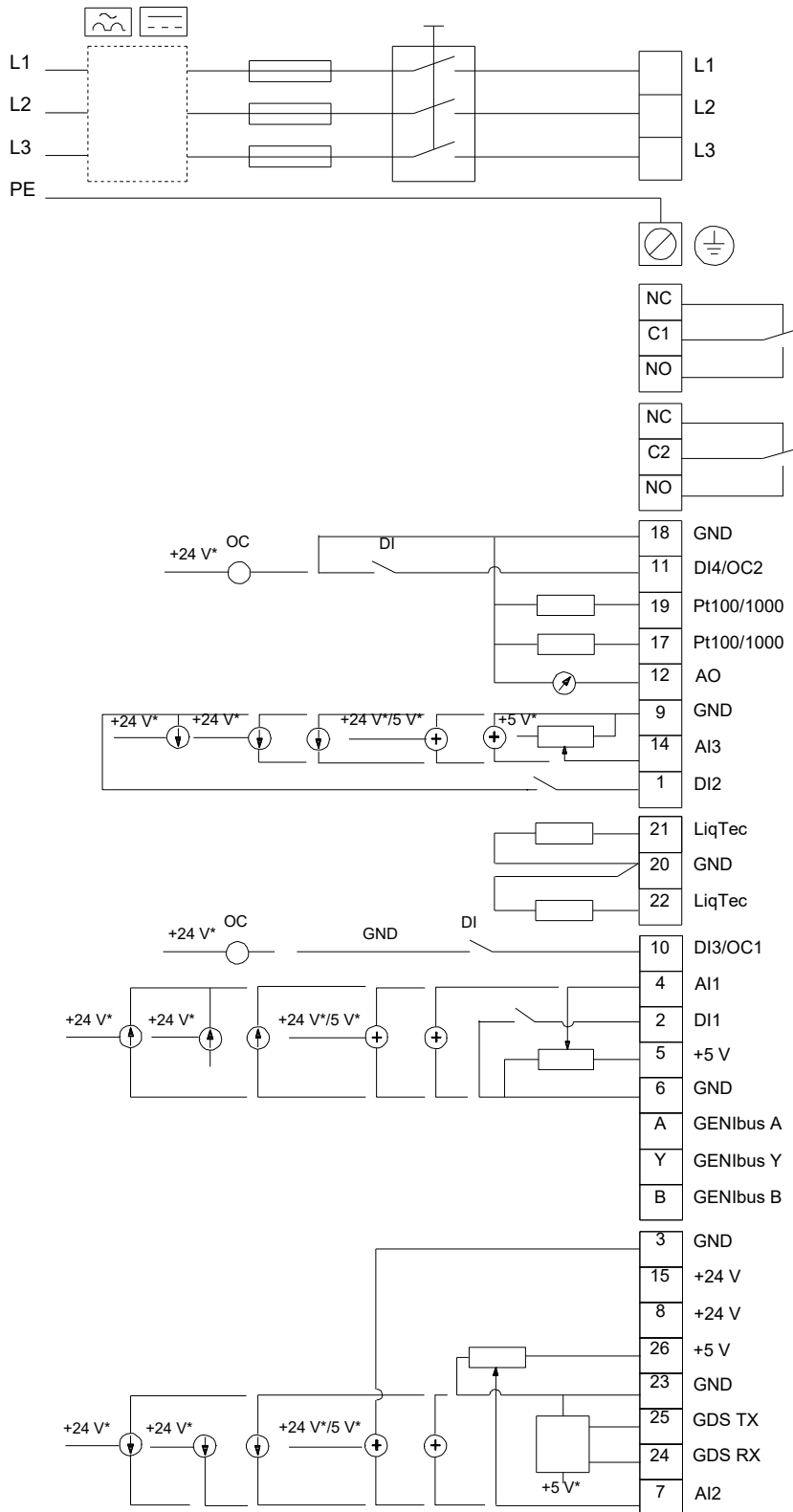

Note! All units are in [mm] unless others are stated.

**Order Data:**

<b>Position</b>	<b>Your pos.</b>	<b>Product name</b>	<b>Amount</b>	<b>Product No</b>	<b>Total</b>
		CRE 32-4-2	1	99071960	Price on request