

Qty. Description

1 NB 32-160/134 AAF2AESBQQECW3



Note! Product picture may differ from actual product

Product No.: [98987646](#)

Non-self-priming, single-stage, centrifugal volute pump designed according to ISO 5199 with dimensions and rated performance according to EN 733 (10 bar).

Flanges are PN 16 with dimensions according to EN 1092-2. The pump has an axial suction port, radial discharge port, horizontal shaft and a back pull-out design enabling removal of the motor, motor stool, cover and impeller without disturbing the pump housing or pipework.

The unbalanced rubber bellows seal is according to DIN EN 12756.

The pump is close-coupled to a fan-cooled asynchronous motor.

The back pull-out design means that the pump can be serviced by a single person without disturbing the pump housing or pipes.

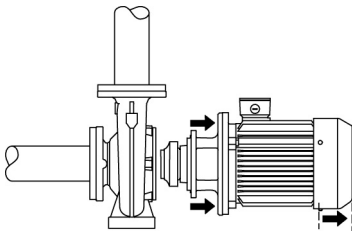

Cast-iron parts have an epoxy-based coating made in a cathodic electro-deposition (CED) process. CED is a high-quality dip-painting process where an electrical field around the products ensures deposition of paint particles as a thin, well-controlled layer on the surface.

Pump

Motor stool and pump cover are made of cast iron (EN-GJL-250). Coupling guards are fitted to the motor stool.

The pump is fitted with an unbalanced rubber bellows seal with torque transmission across the spring and around the bellows. Due to the bellows, the seal does not wear the shaft, and the axial movement is not prevented by deposits on the shaft.

Seal faces:

- Rotating seal ring material: silicon carbide (SiC)
- Stationary seat material: silicon carbide (SiC)

This material pairing is used where higher corrosion resistance is required. The high hardness of this material pairing offers good resistance against abrasive particles.

Secondary seal material: EPDM (ethylene-propylene rubber)

EPDM has excellent resistance to hot water. EPDM is not suitable for mineral oils.

The pump housing has feet.

Motor

The motor is a totally enclosed, fan-cooled motor with principal dimensions to IEC and DIN standards. Electrical tolerances comply with IEC 60034.

The motor efficiency is classified as IE2 in accordance with IEC 60034-30.

The motor does not incorporate motor protection and must be connected to a motor-protective circuit breaker which can be manually reset. The motor-protective circuit breaker must be set according to the rated current of the motor (I1/1).

Qty. Description

1 Further product details

Cast-iron parts have an epoxy-based coating made in a cathodic electro-deposition (CED) process. CED is a high-quality dip-painting process where an electrical field around the products ensures deposition of paint particles as a thin, well-controlled layer on the surface.

Technical data

Controls:

Frequency converter: NONE

Pressure sensor: N

Liquid:

Pumped liquid: Water

Liquid temperature range: -25 .. 120 °C

Selected liquid temperature: 20 °C

Density: 998.2 kg/m³

Technical:

Pump speed on which pump data are based: 1420 rpm

Rated flow: 10.28 m³/h

Rated head: 4.508 m

Actual impeller diameter: 134 mm

Nominal impeller diameter: 160

Shaft seal arrangement: Single

Code for shaft seal: BQQE

Curve tolerance: ISO9906:2012 3B2

Bearing design: Standard

Materials:

Pump housing: Cast iron
EN-GJL-250
ASTM class 35

Wear ring: Brass

Impeller: Cast iron
EN-GJL-200
ASTM class 30

Internal pump house coating: CED

Shaft: Stainless steel
EN 1.4301
AISI 304

Installation:

Max. ambient temperature: 40 °C

Maximum operating pressure: 16 bar

Pipe connection standard: EN 1092-2

Size of inlet connection: DN 50

Size of outlet connection: DN 32

Pressure rating for connection: PN 16

Bearing lubrication: Grease

Pump housing with feet: Yes

Support block (Yes/No): N

Electrical data:

Motor type: 71A

IE Efficiency class: IE2

Rated power - P2: 0.25 kW

Mains frequency: 50 Hz

Rated voltage: 3 x 220-240D/380-415Y V

Qty.	Description
------	-------------

1	Rated current: 1,30-1,42/0,75-0,82 A
	Starting current: 410 %
	Cos phi - power factor: 0.73-0.64
	Rated speed: 1410-1430 rpm
	Efficiency: IE2 72,4% - IE2 70,0%
	Motor efficiency at full load: 72.4-70.0 %
	Motor efficiency at 3/4 load: 72.6 %
	Motor efficiency at 1/2 load: 68.3 %
	Number of poles: 4
	Enclosure class (IEC 34-5): 55 Dust/Jetting
	Insulation class (IEC 85): F
	Motor No: 99928169
	Bearing insulation type N-end: STEEL BEARING
	Others:
	Minimum efficiency index, MEI \geq : 0.65
	Net weight: 31 kg
	Gross weight: 41 kg
	Shipping volume: 0.134 m ³
	Danish VVS No.: 386060161
	Country of origin: HU
	Custom tariff no.: 84137051

98987646 NB 32-160/134 AAF2AESBQQECW3 50 Hz

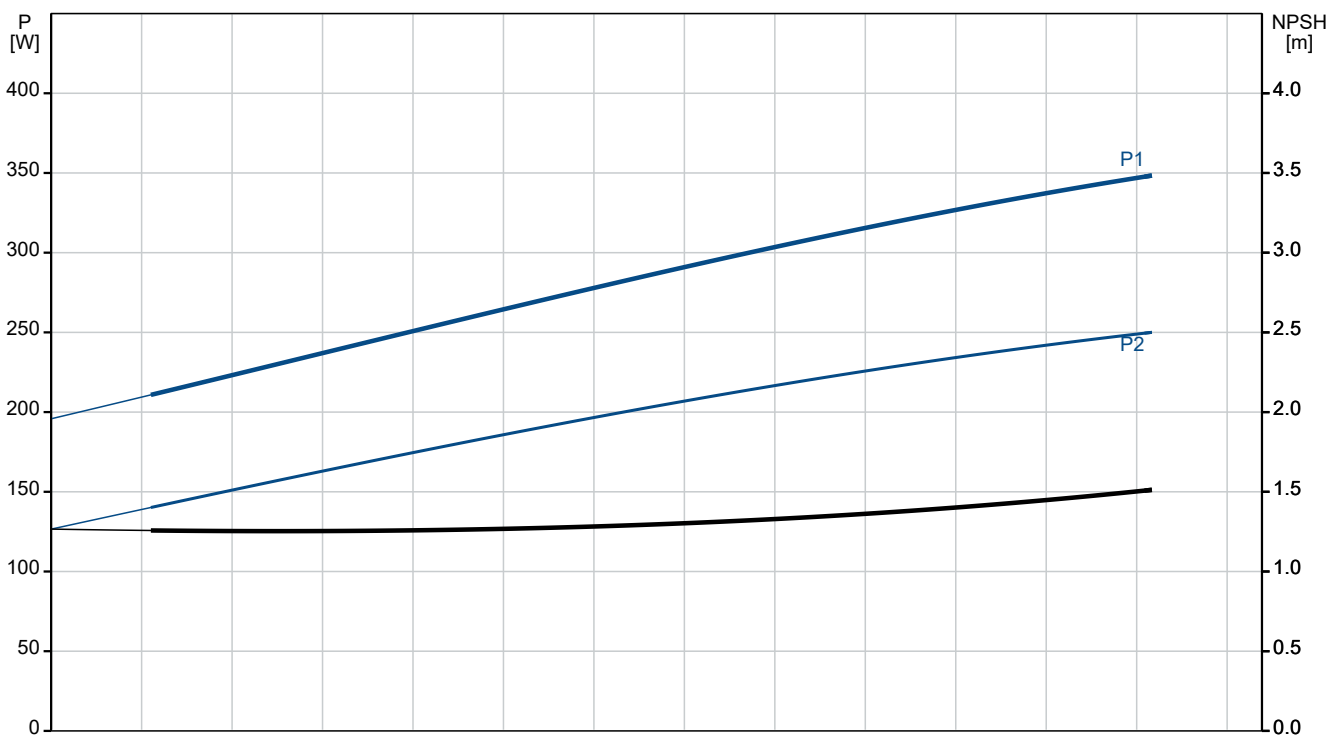
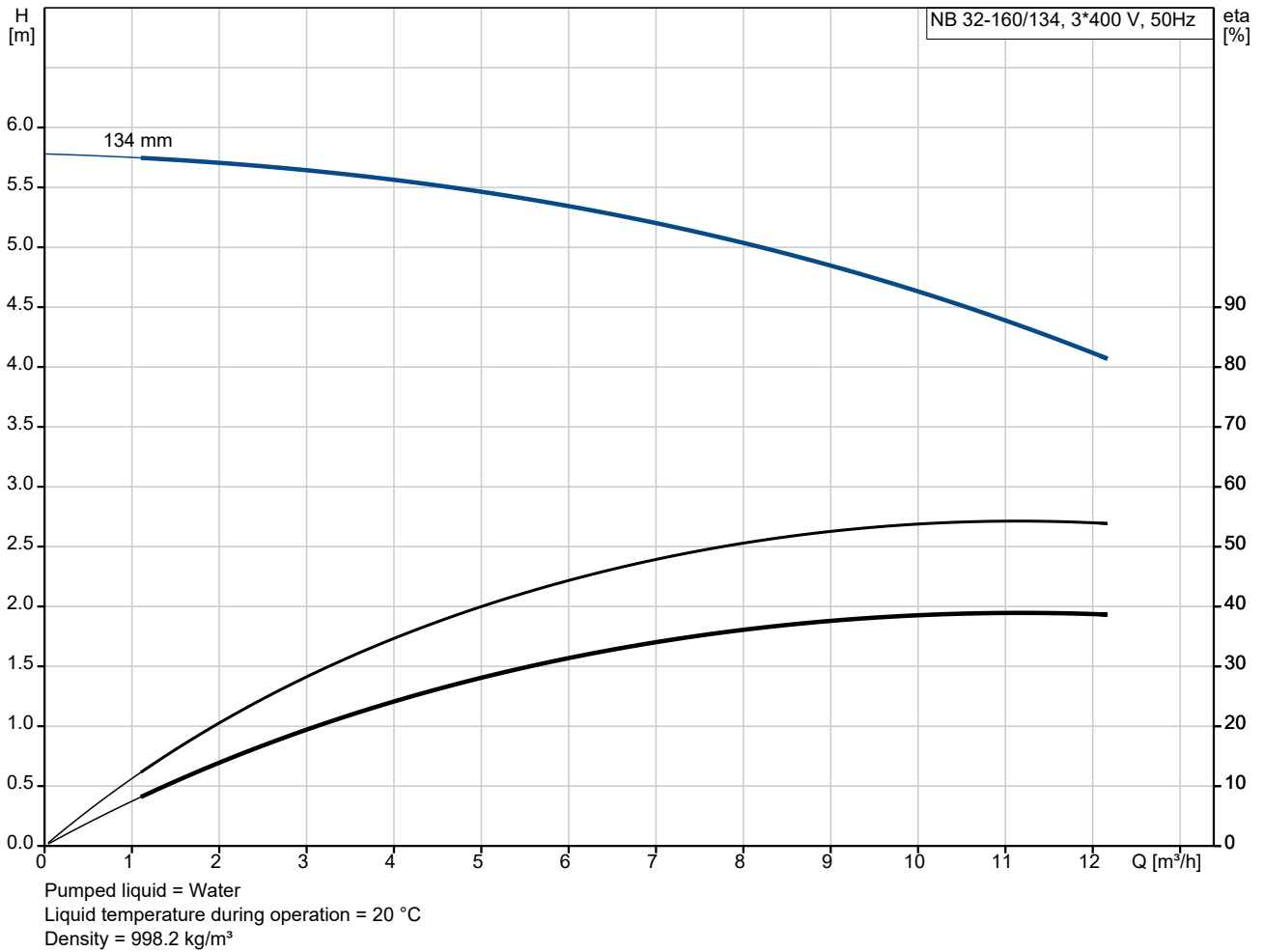

Description	Value
General information:	
Product name:	NB 32-160/134 AAF2AESBQQECW3
Product No:	98987646
EAN number:	5712604745960
Technical:	
Pump speed on which pump data are based:	1420 rpm
Rated flow:	10.28 m ³ /h
Rated head:	4.508 m
Actual impeller diameter:	134 mm
Nominal impeller diameter:	160
Shaft seal arrangement:	Single
Shaft diameter:	24 mm
Code for shaft seal:	BQQE
Curve tolerance:	ISO9906:2012 3B2
Pump version:	A
Bearing design:	Standard
Materials:	
Pump housing:	Cast iron
Pump housing:	EN-GJL-250
Pump housing:	ASTM class 35
Wear ring:	Brass
Impeller:	Cast iron
Impeller:	EN-GJL-200
Impeller:	ASTM class 30
Internal pump house coating:	CED
Material code:	A
Code for rubber:	E
Shaft:	Stainless steel
Shaft:	EN 1.4301
Shaft:	AISI 304
Installation:	
Max. ambient temperature:	40 °C
Maximum operating pressure:	16 bar
Pipe connection standard:	EN 1092-2
Size of inlet connection:	DN 50
Size of outlet connection:	DN 32
Pressure rating for connection:	PN 16
Bearing lubrication:	Grease
Pump housing with feet:	Yes
Support block (Yes/No):	N
Connect code:	F2
Liquid:	
Pumped liquid:	Water
Liquid temperature range:	-25 .. 120 °C
Selected liquid temperature:	20 °C
Density:	998.2 kg/m ³
Electrical data:	
Motor type:	71A
IE Efficiency class:	IE2
Rated power - P2:	0.25 kW
Mains frequency:	50 Hz
Rated voltage:	3 x 220-240D/380-415Y V
Rated current:	1,30-1,42/0,75-0,82 A
Starting current:	410 %
Cos phi - power factor:	0.73-0.64
Rated speed:	1410-1430 rpm
Efficiency:	IE2 72,4% - IE2 70,0%

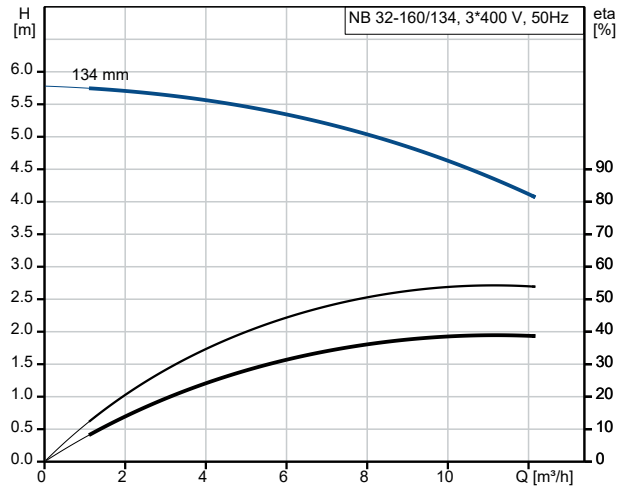

Pumped liquid = Water
Liquid temperature during operation = 20 °C
Density = 998.2 kg/m³

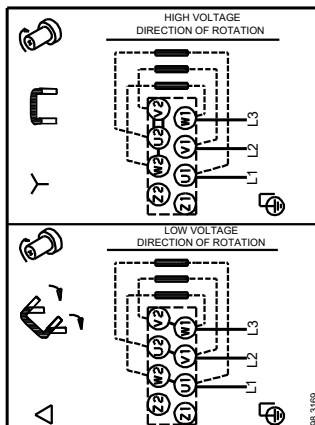
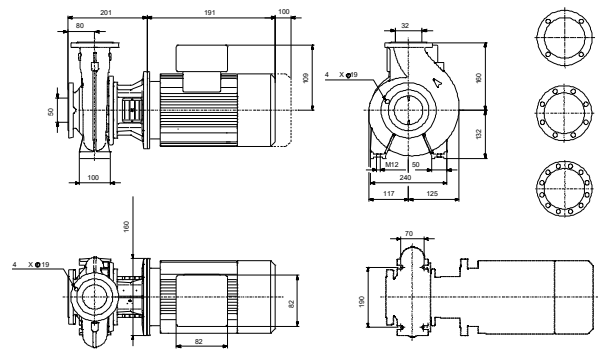
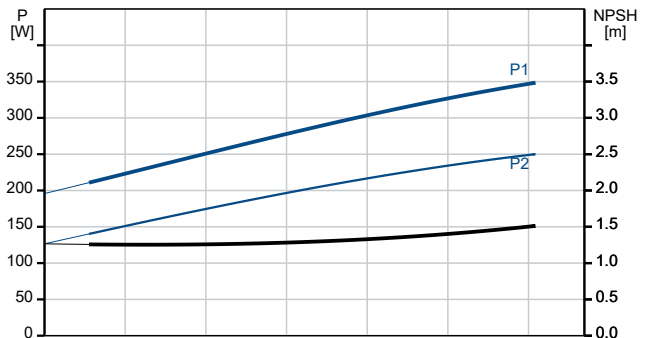



Company name:

Created by:

Phone:

Date:

23/12/2022

Description	Value
Motor efficiency at full load:	72.4-70.0 %
Motor efficiency at 3/4 load:	72.6 %
Motor efficiency at 1/2 load:	68.3 %
Number of poles:	4
Enclosure class (IEC 34-5):	55 Dust/Jetting
Insulation class (IEC 85):	F
Built-in motor protection:	NONE
Motor No:	99928169
Mount. design. acc. IEC 34-7:	IM V1/B5
Bearing insulation type N-end:	STEEL BEARING
Controls:	
Frequency converter:	NONE
Pressure sensor:	N
Others:	
Minimum efficiency index, MEI \geq :	0.65
Net weight:	31 kg
Gross weight:	41 kg
Shipping volume:	0.134 m ³
Danish VVS No.:	386060161
Country of origin:	HU
Custom tariff no.:	84137051

98987646 NB 32-160/134 AAF2AESBQQECW3 50 Hz

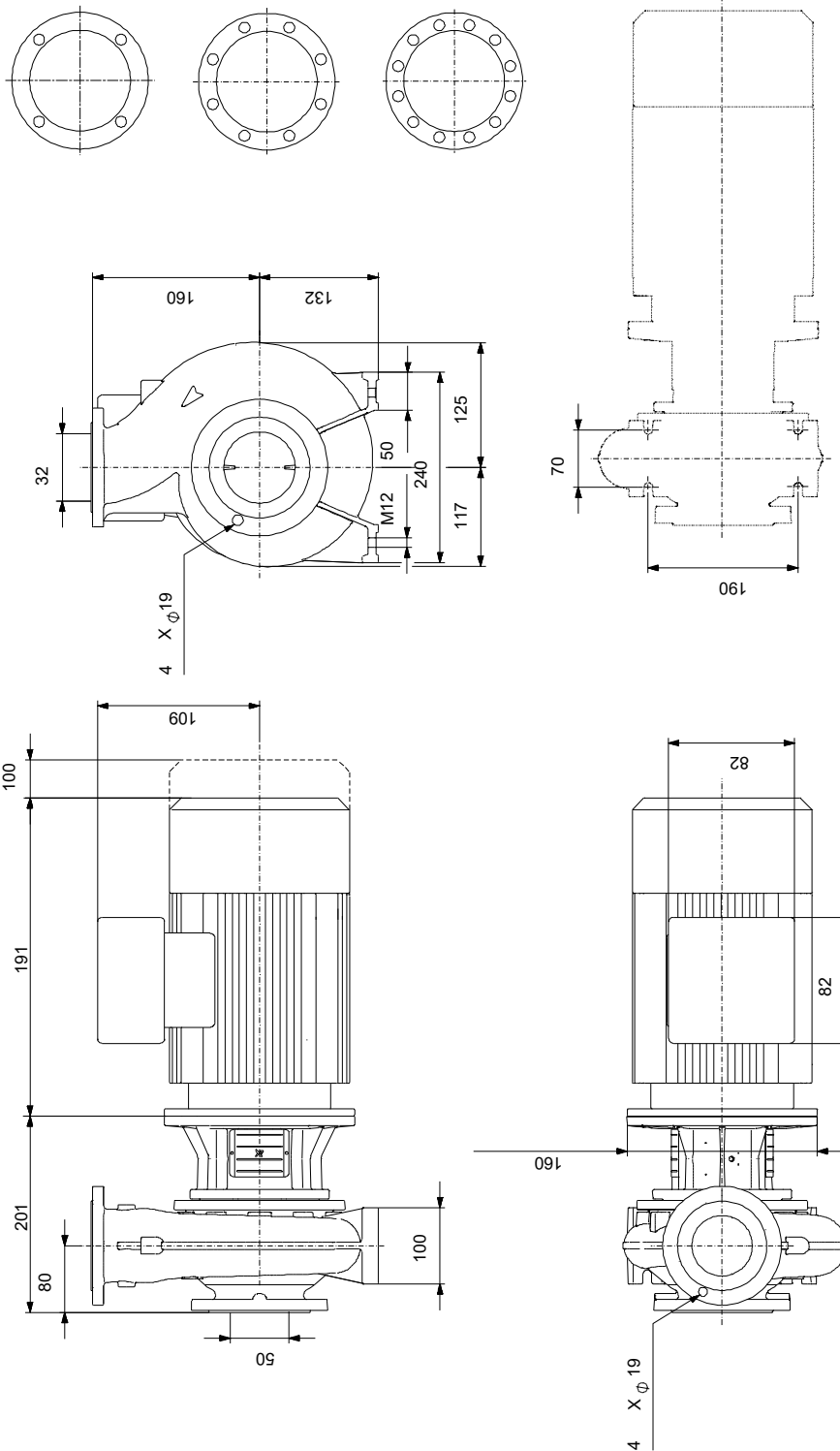

Note! All units are in [mm] unless others are stated.
Disclaimer: This simplified dimensional drawing does not show all details.

98987646 NB 32-160/134 AAF2AESBQQECW3 50 Hz



Note! All units are in [mm] unless others are stated.

