

Qty. Description

1 NK 100-250/216 BA2F2AESBQQEIW5



Note! Product picture may differ from actual product

Product No.: [98973202](#)

Non-self-priming, single-stage, centrifugal pump designed according to ISO 5199 with dimensions and rated performance according to EN 733. Flanges are PN 16 with dimensions according to EN 1092-2. The pump has an axial suction port, a radial discharge port and horizontal shaft. It is of the back pull-out design enabling removal of the coupling, bearing bracket and impeller without disturbing the motor, pump housing or pipework.

The unbalanced rubber bellows seal is according to DIN EN 12756.

The pump is fitted with a foot-mounted, fan-cooled asynchronous motor. Pump and motor are mounted on a common base frame.

The product's minimum efficiency index (MEI) is greater or equal to 0.70. This is by the Commission Regulation (EU) considered as an indicative benchmark for best-performing water pump available on the market as from 1 January 2013.

Pump and motor are mounted on a common steel base frame in accordance with ISO 3661.

The back pull-out design together with a spacer coupling makes it possible to service the pump without dismantling the pump housing and motor from the base frame.

This saves realignment of pump and motor after service.

- 1) Remove coupling.
- 2) Remove the bolts in the bearing bracket support foot.
- 3) Remove the bearing bracket from the pump housing.

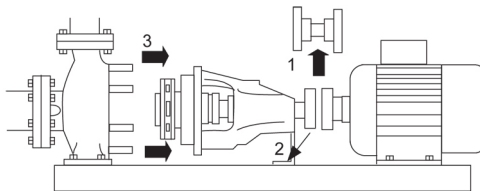
**Pump**

The pump is fitted with an unbalanced rubber bellows seal with torque transmission across the spring and around the bellows. Due to the bellows, the seal does not wear the shaft, and the axial movement is not prevented by deposits on the shaft.

{IMG Filename: GRALON_NB-NK-G_SHAFTSEAL_Bxxx.gif }

Seal faces:

- Rotating seal ring material: silicon carbide (SiC)
- Stationary seat material: silicon carbide (SiC)

This material pairing is used where higher corrosion resistance is required. The high hardness of this material pairing offers good resistance against abrasive particles.

Secondary seal material: EPDM (ethylene-propylene rubber)

EPDM has excellent resistance to hot water. EPDM is not suitable for mineral oils.

The shaft is made of stainless steel and has a diameter of 32 mm where the coupling is mounted.

The pump uses a spacer coupling between the pump and motor shaft.

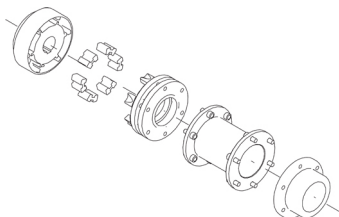
**Motor**

Qty.	Description
1	<p>The motor is a totally enclosed, fan-cooled motor with principal dimensions to IEC and DIN standards. Electrical tolerances comply with IEC 60034.</p> <p>The motor efficiency is classified as IE3 in accordance with IEC 60034-30-1.</p> <p>The motor does not incorporate motor protection and must be connected to a motor-protective circuit breaker which can be manually reset. The motor-protective circuit breaker must be set according to the rated current of the motor (I1/1).</p> <p>The motor can be connected to a variable speed drive for adjustment of pump performance to any duty point. Grundfos CUE offers a range of variable speed drives. Please find more information in Grundfos Product Center.</p> <p>Further product details</p> <p>Cast-iron parts have an epoxy-based coating made in a cathodic electro-deposition (CED) process. CED is a high-quality dip-painting process where an electrical field around the products ensures deposition of paint particles as a thin, well-controlled layer on the surface.</p> <p>Technical data</p> <p>Controls:</p> <p>Frequency converter: NONE</p> <p>Pressure sensor: N</p> <p>Liquid:</p> <p>Pumped liquid: Water</p> <p>Liquid temperature range: -25 .. 120 °C</p> <p>Selected liquid temperature: 20 °C</p> <p>Density: 998.2 kg/m³</p> <p>Technical:</p> <p>Pump speed on which pump data are based: 970 rpm</p> <p>Rated flow: 97.7 m³/h</p> <p>Pump with motor (Yes/No): Y</p> <p>Rated head: 5.6 m</p> <p>Actual impeller diameter: 216 mm</p> <p>Nominal impeller diameter: 250</p> <p>Code for shaft seal: BQQE</p> <p>Mechanical seal type: Single</p> <p>Curve tolerance: ISO9906:2012 3B2</p> <p>Bearing design: Standard</p> <p>Materials:</p> <p>Pump housing: Cast iron EN-GJL-250 ASTM class 35</p> <p>Wear ring: Brass</p> <p>Impeller: Cast iron EN-GJL-200 ASTM class 30</p> <p>Internal pump house coating: CED</p> <p>Shaft: Stainless steel EN 1.4301 AISI 304</p> <p>Installation:</p> <p>t max amb: 55 °C</p> <p>Maximum operating pressure: 16 bar</p> <p>Pipe connection standard: EN 1092-2</p> <p>Type of inlet connection: DIN</p> <p>Type of outlet connection: DIN</p> <p>Size of inlet connection: DN 125</p> <p>Size of outlet connection: DN 100</p> <p>Pressure rating for connection: PN 16</p> <p>Coupling type: Flexible w/spacer</p> <p>Base frame design: EN/ISO</p> <p>Code for base frame: 7</p>

Qty.	Description
1	<p data-bbox="204 163 587 185">Grouting (Yes/No): N</p> <p data-bbox="204 226 363 248">Electrical data:</p> <p data-bbox="204 253 676 275">Motor type: SIEMENS</p> <p data-bbox="204 280 603 302">IE Efficiency class: IE3</p> <p data-bbox="204 306 643 329">Rated power - P2: 2.2 kW</p> <p data-bbox="204 333 632 356">Mains frequency: 50 Hz</p> <p data-bbox="204 360 847 383">Rated voltage: 3 x 220-240D/380-420Y V</p> <p data-bbox="204 387 643 409">Rated current: 8.7/5 A</p> <p data-bbox="204 414 684 436">Starting current: 560-560 %</p> <p data-bbox="204 441 616 463">Cos phi - power factor: 0.75</p> <p data-bbox="204 468 655 490">Rated speed: 970 rpm</p> <p data-bbox="204 495 679 517">Efficiency: IE3 84,3%</p> <p data-bbox="204 521 699 544">Motor efficiency at full load: 84.3-84.3 %</p> <p data-bbox="204 548 655 571">Motor efficiency at 3/4 load: 85-85 %</p> <p data-bbox="204 575 699 598">Motor efficiency at 1/2 load: 83.9-83.9 %</p> <p data-bbox="204 602 576 624">Number of poles: 6</p> <p data-bbox="204 629 619 651">Enclosure class (IEC 34-5): IP55</p> <p data-bbox="204 656 576 678">Insulation class (IEC 85): F</p> <p data-bbox="204 683 671 705">Motor No: 98957421</p> <p data-bbox="204 710 759 732">Bearing insulation type N-end: STEEL BEARING</p> <p data-bbox="204 772 284 795">Others:</p> <p data-bbox="204 799 635 822">Minimum efficiency index, MEI ≥: 0.70</p> <p data-bbox="204 826 639 848">Net weight: 263 kg</p> <p data-bbox="204 853 639 875">Gross weight: 372 kg</p> <p data-bbox="204 880 651 902">Shipping volume: 1.11 m³</p> <p data-bbox="204 907 603 929">Country of origin: HU</p> <p data-bbox="204 934 676 956">Custom tariff no.: 84137059</p>

98973202 NK 100-250/216 BA2F2AESBQQEIW5 50 Hz

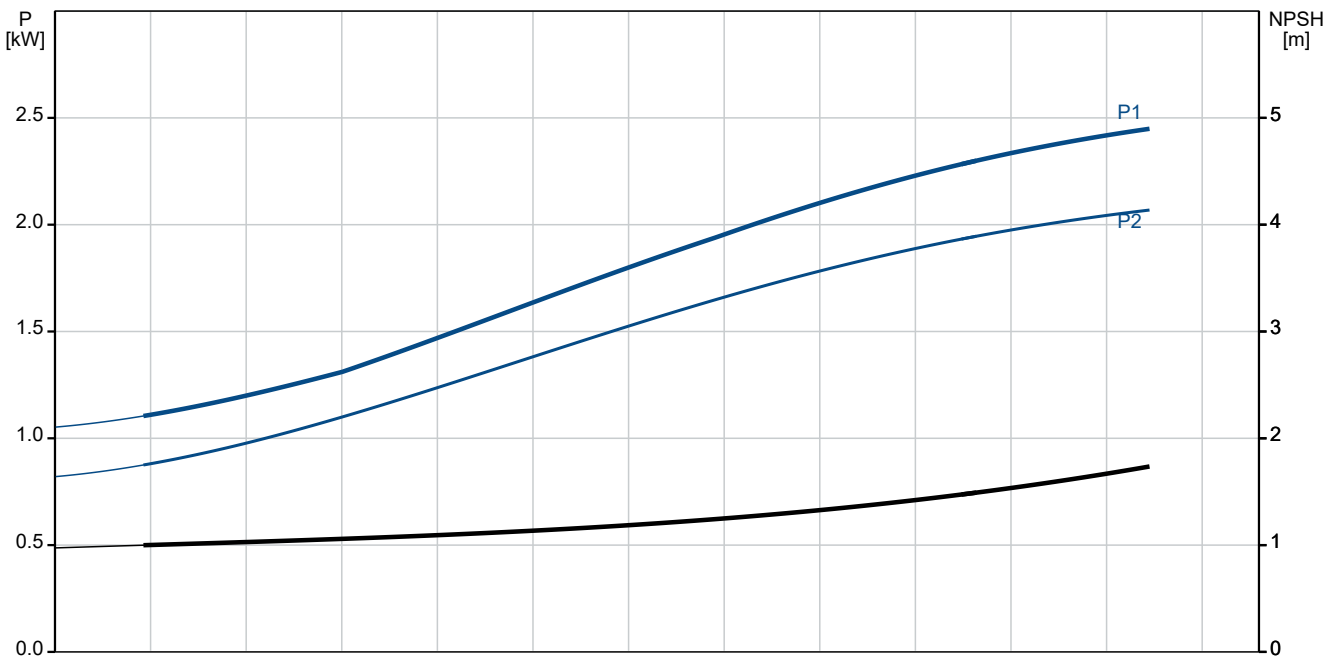
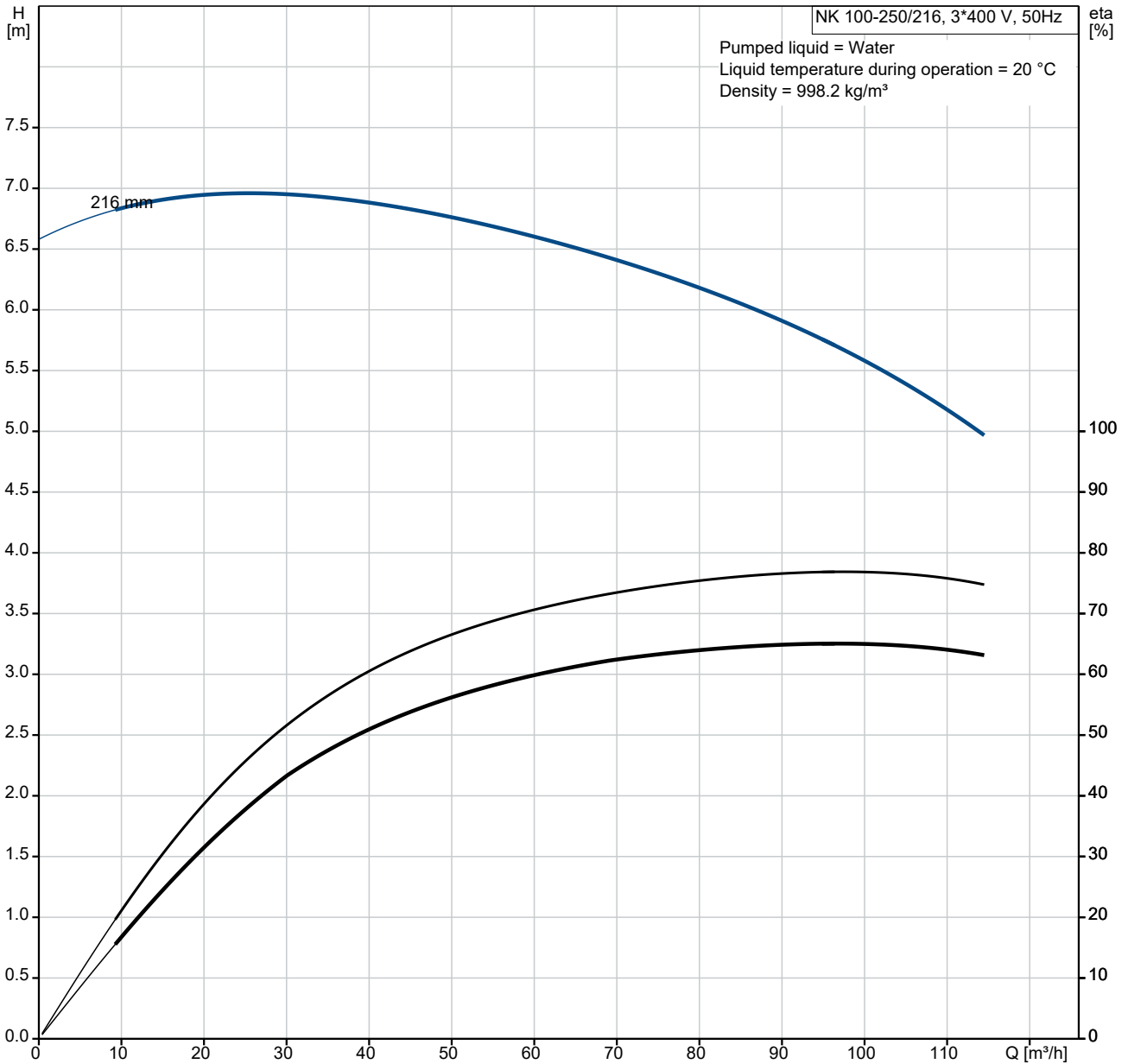

Description	Value
General information:	
Product name:	NK 100-250/216 BA2F2AESBQQEIW5
Product No:	98973202
EAN number:	5712604500637
Technical:	
Pump speed on which pump data are based:	970 rpm
Rated flow:	97.7 m ³ /h
Pump with motor (Yes/No):	Y
Rated head:	5.6 m
Actual impeller diameter:	216 mm
Nominal impeller diameter:	250
Shaft diameter:	32 mm
Code for shaft seal:	BQQE
Mechanical seal type:	Single
Curve tolerance:	ISO9906:2012 3B2
Pump version:	A2
Bearing design:	Standard
Materials:	
Pump housing:	Cast iron
Pump housing:	EN-GJL-250
Pump housing:	ASTM class 35
Wear ring:	Brass
Impeller:	Cast iron
Impeller:	EN-GJL-200
Impeller:	ASTM class 30
Internal pump house coating:	CED
Material code:	A
Code for rubber:	E
Shaft:	Stainless steel
Shaft:	EN 1.4301
Shaft:	AISI 304
Installation:	
t max amb:	55 °C
Maximum operating pressure:	16 bar
Pipe connection standard:	EN 1092-2
Type of inlet connection:	DIN
Type of outlet connection:	DIN
Size of inlet connection:	DN 125
Size of outlet connection:	DN 100
Pressure rating for connection:	PN 16
Coupling type:	Flexible w/spacer
Base frame design:	EN/ISO
Code for base frame:	7
Grouting (Yes/No):	N
Connect code:	F
Liquid:	
Pumped liquid:	Water
Liquid temperature range:	-25 .. 120 °C
Selected liquid temperature:	20 °C
Density:	998.2 kg/m ³
Electrical data:	
Motor type:	SIEMENS
IE Efficiency class:	IE3
Rated power - P2:	2.2 kW
Mains frequency:	50 Hz
Rated voltage:	3 x 220-240D/380-420Y V
Rated current:	8.7/5 A
Starting current:	560-560 %
Cos phi - power factor:	0.75
Rated speed:	970 rpm
Efficiency:	IE3 84,3%
Motor efficiency at full load:	84.3-84.3 %

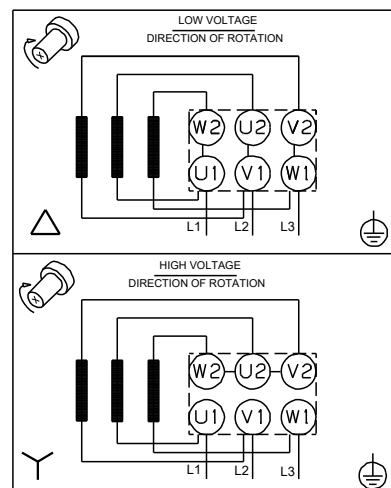
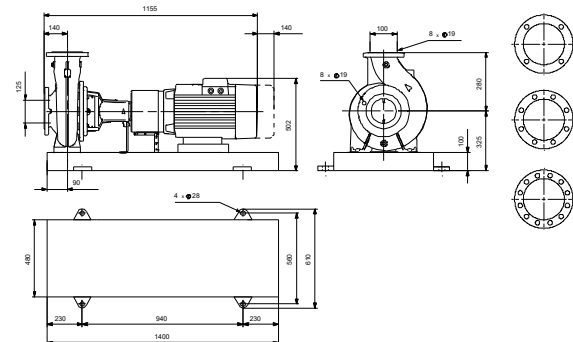
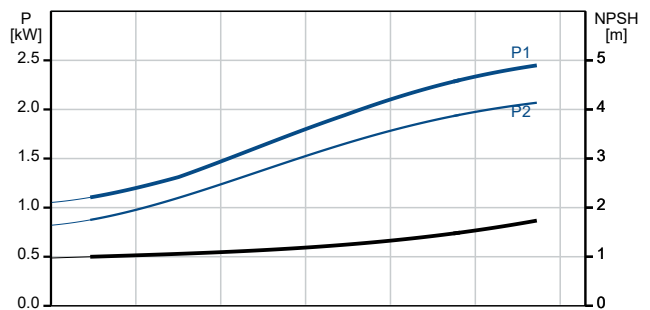
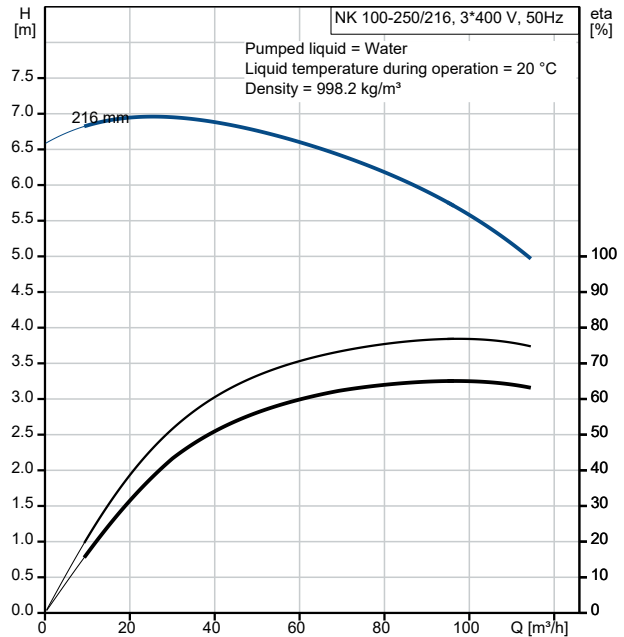

Description	Value
Motor efficiency at 3/4 load:	85-85 %
Motor efficiency at 1/2 load:	83.9-83.9 %
Number of poles:	6
Enclosure class (IEC 34-5):	IP55
Insulation class (IEC 85):	F
Built-in motor protection:	NONE
Motor No:	98957421
Bearing insulation type N-end:	STEEL BEARING
Controls:	
Frequency converter:	NONE
Pressure sensor:	N
Others:	
Minimum efficiency index, MEI ≥:	0.70
Net weight:	263 kg
Gross weight:	372 kg
Shipping volume:	1.11 m ³
Country of origin:	HU
Custom tariff no.:	84137059

98973202 NK 100-250/216 BA2F2AESBQQEIW5 50 Hz

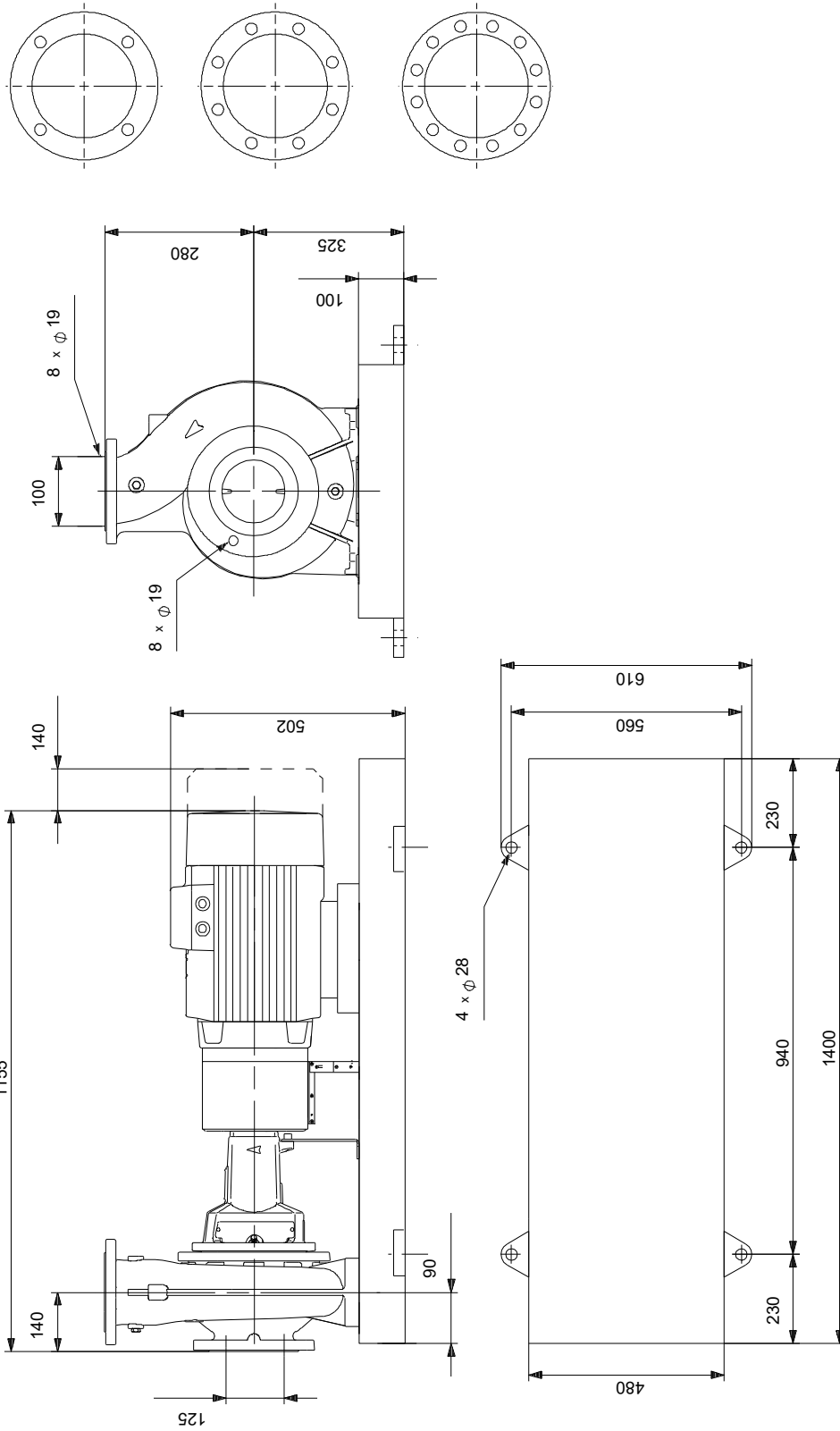

Note! All units are in [mm] unless others are stated.
Disclaimer: This simplified dimensional drawing does not show all details.

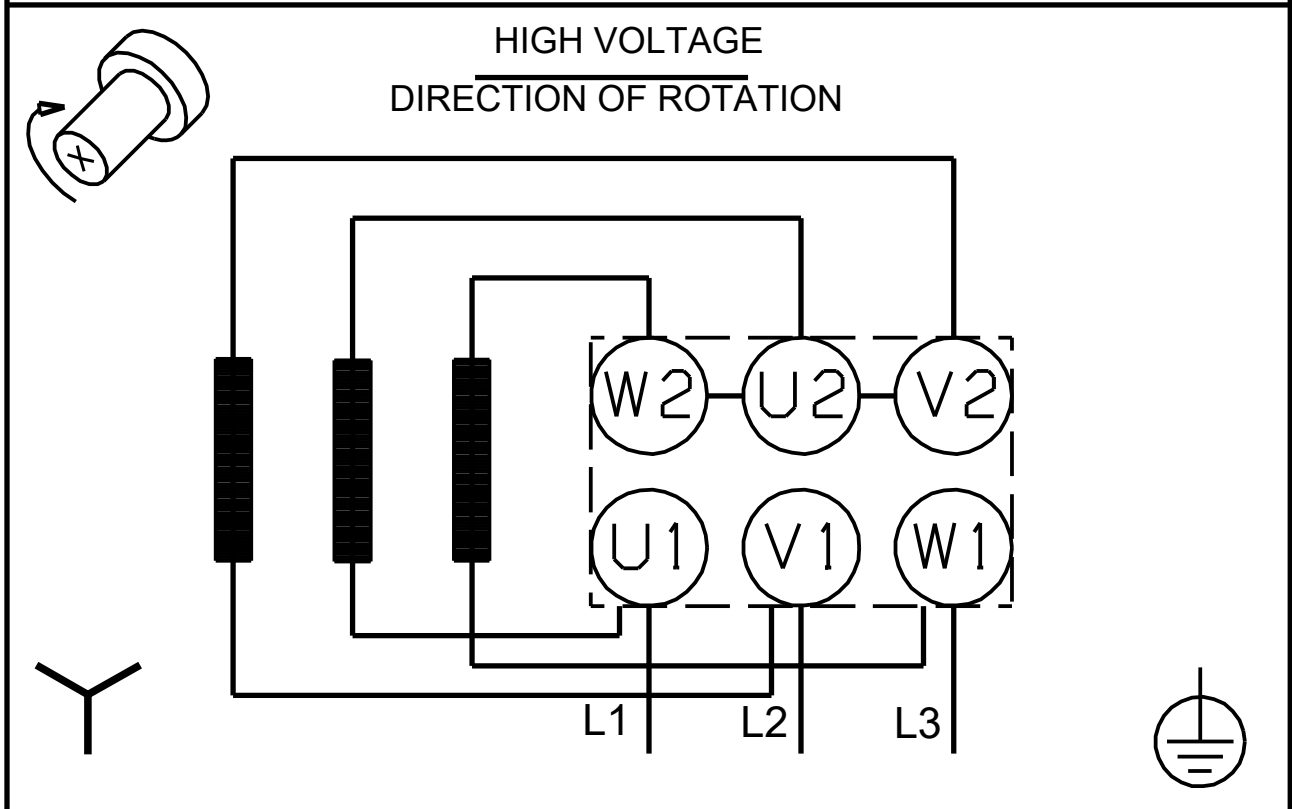
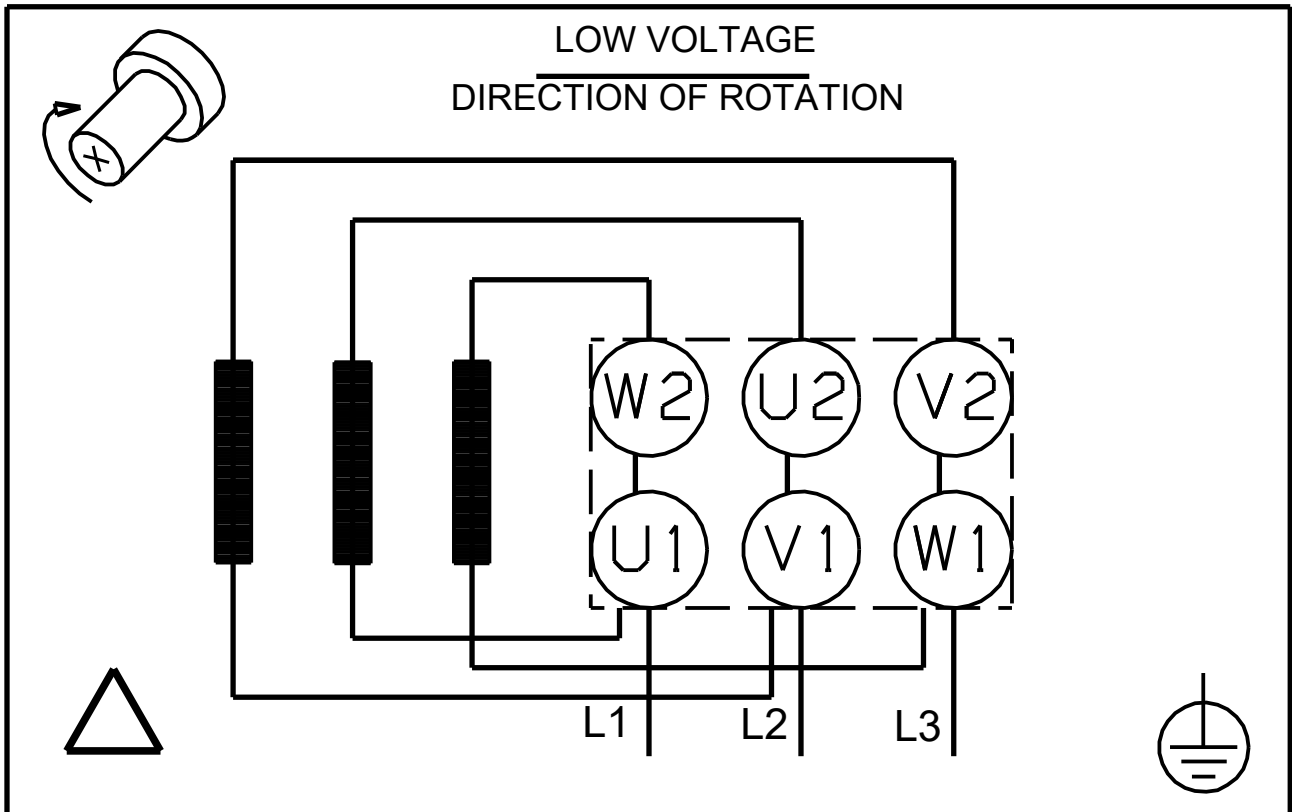

Note! All units are in [mm] unless others are stated.

