

Qty. Description

1 NK 125-250/269 AA2F2AESBQQEYW1



Note! Product picture may differ from actual product

Product No.: [98972904](#)

Non-self-priming, single-stage, centrifugal pump designed according to ISO 5199 with dimensions and rated performance according to EN 733. Flanges are PN 16 with dimensions according to EN 1092-2. The pump has an axial suction port, a radial discharge port and horizontal shaft. It is of the back pull-out design enabling removal of the coupling, bearing bracket and impeller without disturbing the motor, pump housing or pipework.

The unbalanced rubber bellows seal is according to DIN EN 12756.

The pump is fitted with a foot-mounted, fan-cooled asynchronous motor. Pump and motor are mounted on a common base frame.

Pump and motor are mounted on a common steel base frame in accordance with ISO 3661.

The back pull-out design together with a spacer coupling makes it possible to service the pump without dismantling the pump housing and motor from the base frame.

This saves realignment of pump and motor after service.

- 1) Remove coupling.
- 2) Remove the bolts in the bearing bracket support foot.
- 3) Remove the bearing bracket from the pump housing.



Pump

The pump is fitted with an unbalanced rubber bellows seal with torque transmission across the spring and around the bellows. Due to the bellows, the seal does not wear the shaft, and the axial movement is not prevented by deposits on the shaft.

{IMG Filename: GRALON_NB-NK-G_SHAFTSEAL_Bxxx.gif }

Seal faces:

- Rotating seal ring material: silicon carbide (SiC)
- Stationary seat material: silicon carbide (SiC)

This material pairing is used where higher corrosion resistance is required. The high hardness of this material pairing offers good resistance against abrasive particles.

Secondary seal material: EPDM (ethylene-propylene rubber)

EPDM has excellent resistance to hot water. EPDM is not suitable for mineral oils.

The shaft is made of stainless steel and has a diameter of 42 mm where the coupling is mounted.

The pump uses a spacer coupling between the pump and motor shaft.

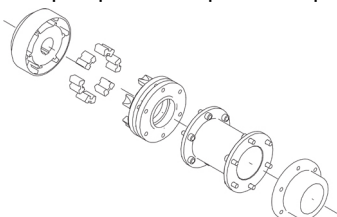

Qty.	Description																																										
1	<p>The base frame is prepared for grouting. Grouting improves the contact of the base frame with the foundation and stiffens the base frame construction. This changes the vibration level.</p> <p>Grouting is mandatory for all base frame types for all 2-pole pumps equal to and above 55 kW to fulfill the max vibration level requirements stated in standards. For other pump motor combinations grouting of the base frame is optional.</p> <p>Motor</p> <p>The motor is a totally enclosed, fan-cooled motor with principal dimensions to IEC and DIN standards. Electrical tolerances comply with IEC 60034.</p> <p>The motor efficiency is classified as IE3 in accordance with IEC 60034-30-1.</p> <p>The motor has thermistors (PTC sensors) in the windings in accordance with DIN 44081/DIN 44082. The protection reacts to both slow- and quick-rising temperatures, e.g. constant overload and stalled conditions.</p> <p>Thermal switches must be connected to an external control circuit in a way which ensures that the automatic reset cannot cause accidents. The motors must be connected to a motor-protective circuit breaker according to local regulations.</p> <p>A variable speed drive makes adjustment of pump performance to any duty point possible. If the motor is to be connected to a variable speed drive, the pump must be ordered with an electrically insulated motor bearing.</p> <p>Further product details</p> <p>Cast-iron parts have an epoxy-based coating made in a cathodic electro-deposition (CED) process. CED is a high-quality dip-painting process where an electrical field around the products ensures deposition of paint particles as a thin, well-controlled layer on the surface.</p> <p>Technical data</p> <p>Controls:</p> <table data-bbox="199 1167 638 1227"> <tr> <td>Frequency converter:</td> <td>NONE</td> </tr> <tr> <td>Pressure sensor:</td> <td>N</td> </tr> </table> <p>Liquid:</p> <table data-bbox="199 1285 702 1406"> <tr> <td>Pumped liquid:</td> <td>Water</td> </tr> <tr> <td>Liquid temperature range:</td> <td>-25 .. 120 °C</td> </tr> <tr> <td>Selected liquid temperature:</td> <td>20 °C</td> </tr> <tr> <td>Density:</td> <td>998.2 kg/m³</td> </tr> </table> <p>Technical:</p> <table data-bbox="199 1464 821 1765"> <tr> <td>Pump speed on which pump data are based:</td> <td>2982 rpm</td> </tr> <tr> <td>Rated flow:</td> <td>632 m³/h</td> </tr> <tr> <td>Pump with motor (Yes/No):</td> <td>Y</td> </tr> <tr> <td>Rated head:</td> <td>81.73 m</td> </tr> <tr> <td>Actual impeller diameter:</td> <td>269 mm</td> </tr> <tr> <td>Nominal impeller diameter:</td> <td>250</td> </tr> <tr> <td>Code for shaft seal:</td> <td>BQQE</td> </tr> <tr> <td>Mechanical seal type:</td> <td>Single</td> </tr> <tr> <td>Curve tolerance:</td> <td>ISO9906:2012 3B</td> </tr> <tr> <td>Bearing design:</td> <td>Standard</td> </tr> </table> <p>Materials:</p> <table data-bbox="199 1823 734 2089"> <tr> <td>Pump housing:</td> <td>Cast iron EN-GJL-250 ASTM class 35</td> </tr> <tr> <td>Wear ring:</td> <td>Brass</td> </tr> <tr> <td>Impeller:</td> <td>Cast iron EN-GJL-200 ASTM class 30</td> </tr> <tr> <td>Internal pump house coating:</td> <td>CED</td> </tr> <tr> <td>Shaft:</td> <td>Stainless steel</td> </tr> </table>	Frequency converter:	NONE	Pressure sensor:	N	Pumped liquid:	Water	Liquid temperature range:	-25 .. 120 °C	Selected liquid temperature:	20 °C	Density:	998.2 kg/m ³	Pump speed on which pump data are based:	2982 rpm	Rated flow:	632 m ³ /h	Pump with motor (Yes/No):	Y	Rated head:	81.73 m	Actual impeller diameter:	269 mm	Nominal impeller diameter:	250	Code for shaft seal:	BQQE	Mechanical seal type:	Single	Curve tolerance:	ISO9906:2012 3B	Bearing design:	Standard	Pump housing:	Cast iron EN-GJL-250 ASTM class 35	Wear ring:	Brass	Impeller:	Cast iron EN-GJL-200 ASTM class 30	Internal pump house coating:	CED	Shaft:	Stainless steel
Frequency converter:	NONE																																										
Pressure sensor:	N																																										
Pumped liquid:	Water																																										
Liquid temperature range:	-25 .. 120 °C																																										
Selected liquid temperature:	20 °C																																										
Density:	998.2 kg/m ³																																										
Pump speed on which pump data are based:	2982 rpm																																										
Rated flow:	632 m ³ /h																																										
Pump with motor (Yes/No):	Y																																										
Rated head:	81.73 m																																										
Actual impeller diameter:	269 mm																																										
Nominal impeller diameter:	250																																										
Code for shaft seal:	BQQE																																										
Mechanical seal type:	Single																																										
Curve tolerance:	ISO9906:2012 3B																																										
Bearing design:	Standard																																										
Pump housing:	Cast iron EN-GJL-250 ASTM class 35																																										
Wear ring:	Brass																																										
Impeller:	Cast iron EN-GJL-200 ASTM class 30																																										
Internal pump house coating:	CED																																										
Shaft:	Stainless steel																																										

Qty.	Description
1	<p>EN 1.4301 AISI 304</p> <p>Installation: t max amb: 55 °C Maximum operating pressure: 16 bar Pipe connection standard: EN 1092-2 Type of inlet connection: DIN Type of outlet connection: DIN Size of inlet connection: DN 150 Size of outlet connection: DN 125 Pressure rating for connection: PN 16 Coupling type: Flexible w/spacer Base frame design: EN/ISO Code for base frame: 10 Grouting (Yes/No): Y</p> <p>Electrical data: Motor type: SIEMENS IE Efficiency class: IE3 Rated power - P2: 200 kW Mains frequency: 50 Hz Rated voltage: 3 x 380-420D/660-725Y V Rated current: 330/190 A Starting current: 720-720 % Cos phi - power factor: 0.92 Rated speed: 2982 rpm Efficiency: IE3 95,8% Motor efficiency at full load: 95.8-95.8 % Motor efficiency at 3/4 load: 95.9-95.9 % Motor efficiency at 1/2 load: 95.5-95.5 % Number of poles: 2 Enclosure class (IEC 34-5): IP55 Insulation class (IEC 85): F Motor No: 98943385 Bearing insulation type N-end: STEEL BEARING</p> <p>Others: Minimum efficiency index, MEI ≥: 0.49 Net weight: 1670 kg Gross weight: 1770 kg Shipping volume: 2.96 m³</p>

98972904 NK 125-250/269 AA2F2AESBQQEYW1 50 Hz

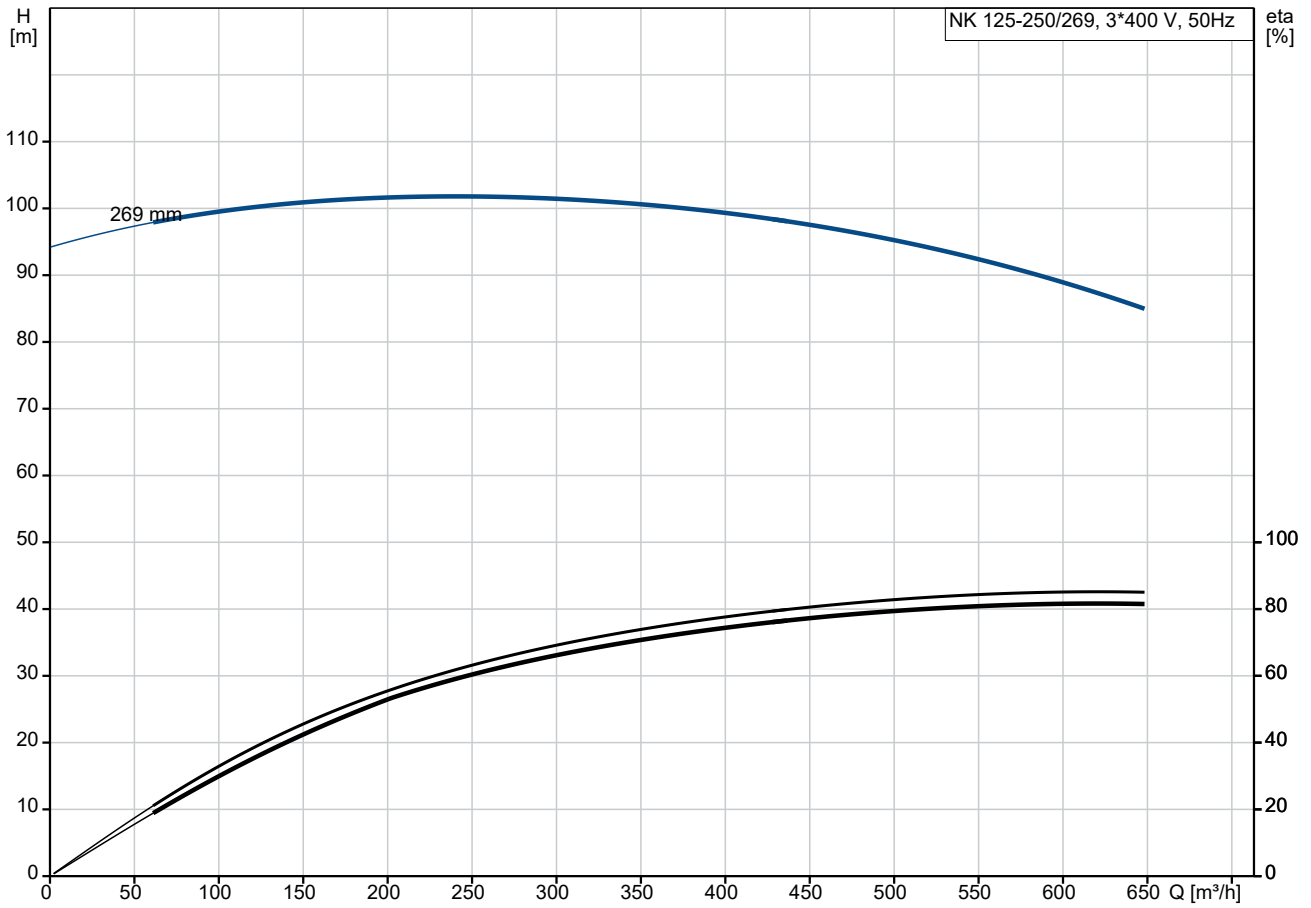

Pumped liquid = Water
 Liquid temperature during operation = 20 °C
 Density = 998.2 kg/m³

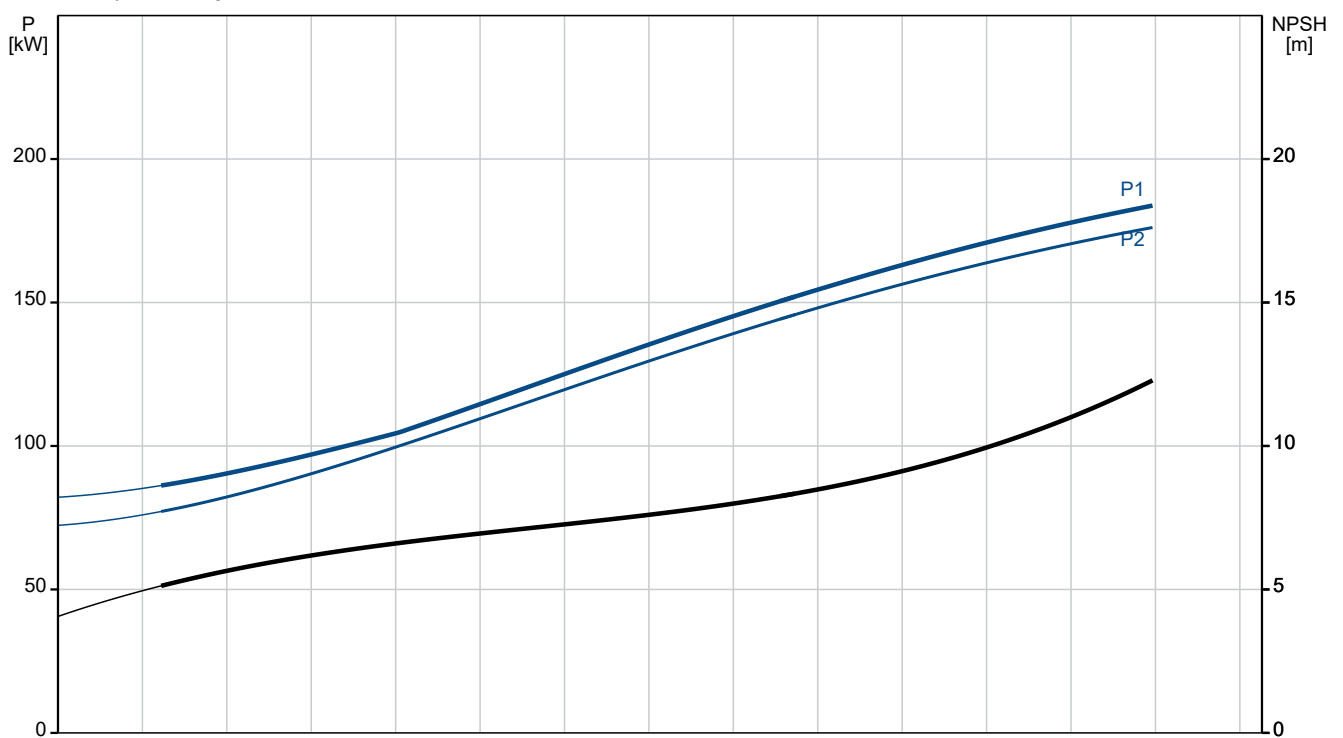

Description	Value
General information:	
Product name:	NK 125-250/269 AA2F2AESBQQEYW1
Product No:	98972904
EAN number:	5712604494509
Technical:	
Pump speed on which pump data are based:	2982 rpm
Rated flow:	632 m ³ /h
Pump with motor (Yes/No):	Y
Rated head:	81.73 m
Actual impeller diameter:	269 mm
Nominal impeller diameter:	250
Shaft diameter:	42 mm
Code for shaft seal:	BQQE
Mechanical seal type:	Single
Curve tolerance:	ISO9906:2012 3B
Pump version:	A2
Bearing design:	Standard
Materials:	
Pump housing:	Cast iron
Pump housing:	EN-GJL-250
Pump housing:	ASTM class 35
Wear ring:	Brass
Impeller:	Cast iron
Impeller:	EN-GJL-200
Impeller:	ASTM class 30
Internal pump house coating:	CED
Material code:	A
Code for rubber:	E
Shaft:	Stainless steel
Shaft:	EN 1.4301
Shaft:	AISI 304
Installation:	
t max amb:	55 °C
Maximum operating pressure:	16 bar
Pipe connection standard:	EN 1092-2
Type of inlet connection:	DIN
Type of outlet connection:	DIN
Size of inlet connection:	DN 150
Size of outlet connection:	DN 125
Pressure rating for connection:	PN 16
Coupling type:	Flexible w/spacer
Base frame design:	EN/ISO
Code for base frame:	10
Grouting (Yes/No):	Y
Connect code:	F
Liquid:	
Pumped liquid:	Water
Liquid temperature range:	-25 .. 120 °C
Selected liquid temperature:	20 °C
Density:	998.2 kg/m ³
Electrical data:	
Motor type:	SIEMENS
IE Efficiency class:	IE3
Rated power - P2:	200 kW
Mains frequency:	50 Hz
Rated voltage:	3 x 380-420D/660-725Y V
Rated current:	330/190 A

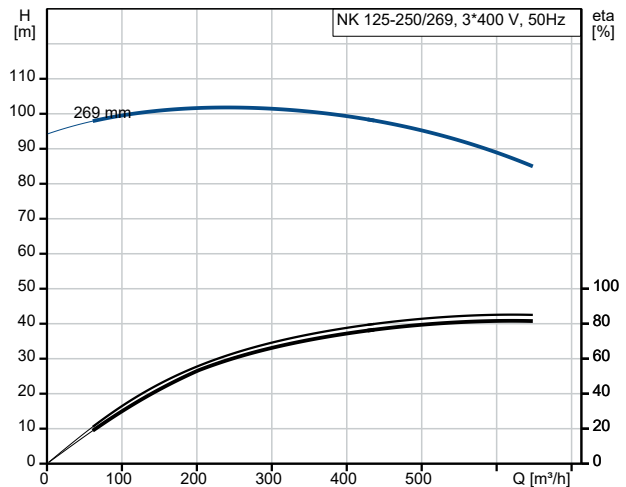

Pumped liquid = Water
Liquid temperature during operation = 20 °C
Density = 998.2 kg/m³

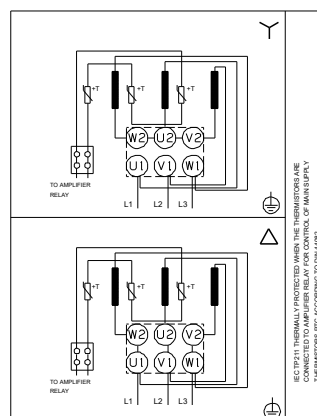
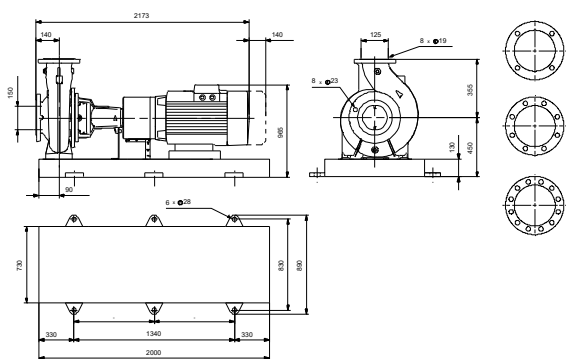
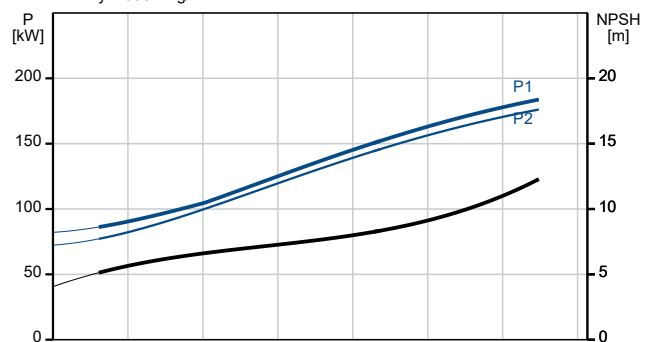



Company name:

Created by:

Phone:

Date:

28/12/2022

Description	Value
Starting current:	720-720 %
Cos phi - power factor:	0.92
Rated speed:	2982 rpm
Efficiency:	IE3 95,8%
Motor efficiency at full load:	95.8-95.8 %
Motor efficiency at 3/4 load:	95.9-95.9 %
Motor efficiency at 1/2 load:	95.5-95.5 %
Number of poles:	2
Enclosure class (IEC 34-5):	IP55
Insulation class (IEC 85):	F
Built-in motor protection:	PTC
Motor No:	98943385
Bearing insulation type N-end:	STEEL BEARING
Controls:	
Frequency converter:	NONE
Pressure sensor:	N
Others:	
Minimum efficiency index, MEI ≥:	0.49
Net weight:	1670 kg
Gross weight:	1770 kg
Shipping volume:	2.96 m ³

98972904 NK 125-250/269 AA2F2AESBQQEYW1 50 Hz

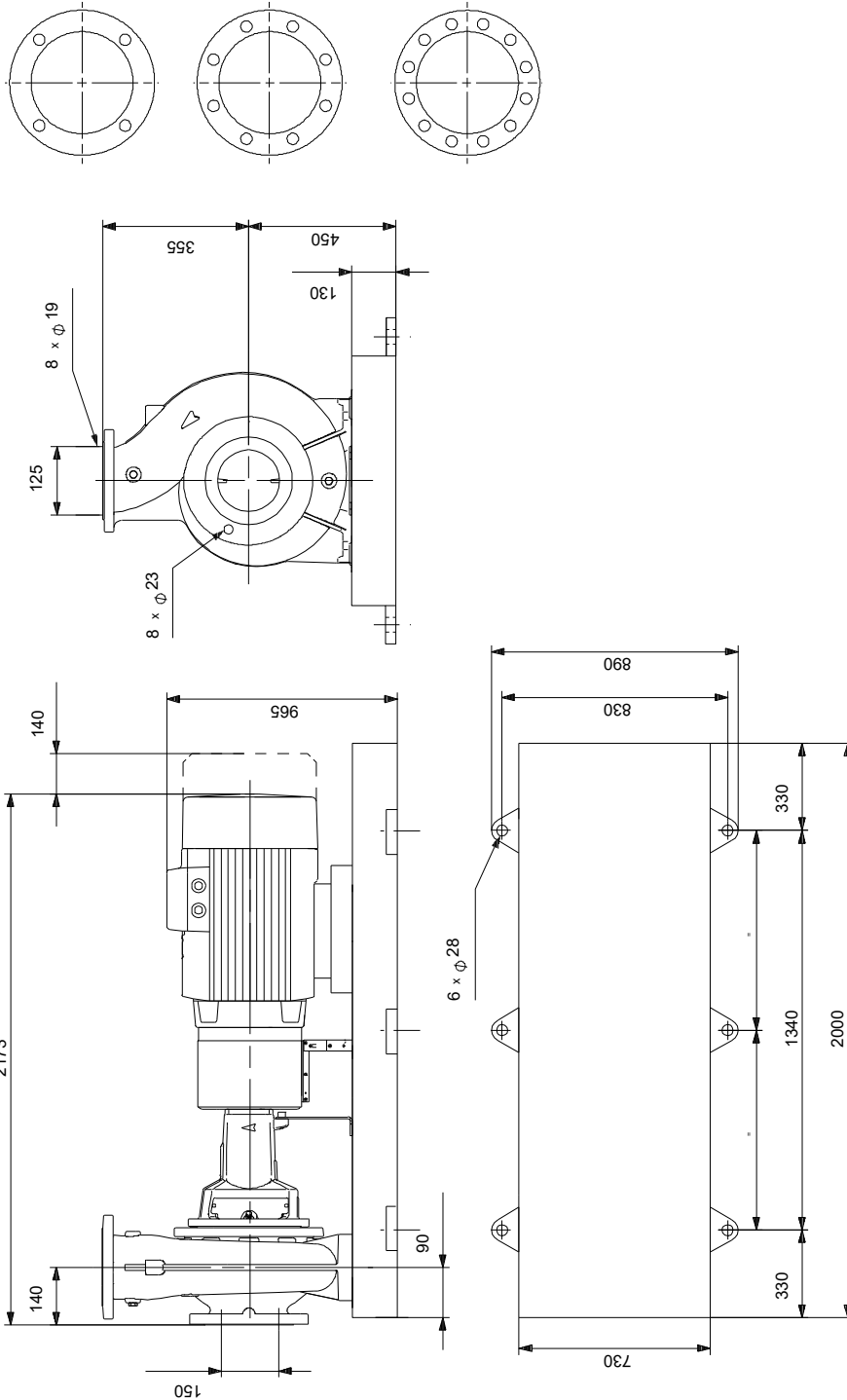

Note! All units are in [mm] unless others are stated.
Disclaimer: This simplified dimensional drawing does not show all details.

98972904 NK 125-250/269 AA2F2AESBQQEYW1 50 Hz



IEC TP211 THERMALLY PROTECTED WHEN THE THERMISTORS ARE
CONNECTED TO AMPLIFIER RELAY FOR CONTROL OF MAIN SUPPLY
THERMISTORS PTC ACCORDING TO DIN 44082

Note! All units are in [mm] unless others are stated.



Company name:
Created by:
Phone:

Date: 28/12/2022

Order Data:

Position	Your pos.	Product name	Amount	Product No	Total
		NK 125-250/269	1	98972904	Price on request