

Qty. Description

1 TP 50-60/2 A-F-A-BQQE-DX1



Note! Product picture may differ from actual product

Product No.: [98182027](#)

Single-stage, close-coupled, volute pump with in-line suction and discharge ports of identical diameter. The pump is of the top-pull-out design, i.e. the power head (motor, pump head and impeller) can be removed for maintenance or service while the pump housing remains in the pipework.

The pump is fitted with an unbalanced rubber bellows seal.

The shaft seal is according to EN 12756. Pipework connection is via PN 6/10 DIN flanges (EN 1092-2 and ISO 7005-2).

The pump is fitted with a fan-cooled asynchronous motor.

Cast-iron parts have an epoxy-based coating made in a cathodic electro-deposition (CED) process. CED is a high-quality dip-painting process where an electrical field around the products ensures deposition of paint particles as a thin, well-controlled layer on the surface.

Pump

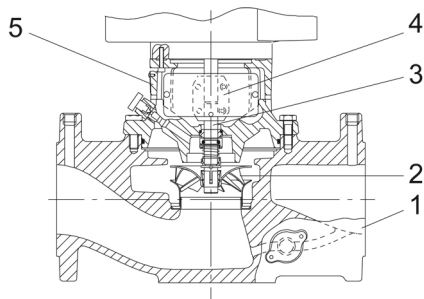

1: Pump housing

2: Impeller

3: Shaft

4: Coupling

5: Pump head

The pump housing is provided with a replaceable stainless steel/PTFE neck ring to reduce the amount of liquid running from the discharge side of the impeller to the suction side.

The impeller is secured with a split cone with nut.

The pump is fitted with an unbalanced rubber bellows seal with torque transmission across the spring and around the bellows. Due to the bellows, the seal does not wear the shaft, and the axial movement is not prevented by deposits on the shaft.

Seal faces:

- Rotating seal ring material: silicon carbide (SiC)
- Stationary seat material: silicon carbide (SiC)

This material pairing is used where higher corrosion resistance is required. The high hardness of this material pairing offers good resistance against abrasive particles.

Secondary seal material: EPDM (ethylene-propylene rubber)

EPDM has excellent resistance to hot water. EPDM is not suitable for mineral oils.

A circulation of liquid through the duct of the air vent screw ensures lubrication and cooling of the shaft seal.

The flanges have tappings for mounting of pressure gauges.

Qty.	Description
	<p>The motor stool forms connection between the pump housing and the motor, and is equipped with a manual air vent screw for venting of the pump housing and the shaft seal chamber. The sealing between motor stool and pump housing is an O-ring.</p> <p>The central part of the motor stool is provided with guards for protection against the shaft and coupling. Motor and pump shaft are connected via a shell coupling.</p> <p>Motor</p> <p>The motor is a totally enclosed, fan-cooled motor with principal dimensions to IEC and DIN standards. Electrical tolerances comply with IEC 60034.</p> <p>The motor is flange-mounted with tapped-hole flange (FT). Motor-mounting designation in accordance with IEC 60034-7: IM B 14, IM V 18 (Code I) / IM 3601, IM 3611 (Code II).</p> <p>The motor efficiency is classified as IE3 in accordance with IEC 60034-30-1.</p> <p>The motor does not incorporate motor protection and must be connected to a motor-protective circuit breaker which can be manually reset. The motor-protective circuit breaker must be set according to the rated current of the motor (I1/1).</p> <p>Further product details</p> <p>Cast-iron parts have an epoxy-based coating made in a cathodic electro-deposition (CED) process. CED is a high-quality dip-painting process where an electrical field around the products ensures deposition of paint particles as a thin, well-controlled layer on the surface.</p> <p>Technical data</p> <p>Controls:</p> <p>Frequency converter: NONE</p> <p>Liquid:</p> <p>Pumped liquid: Water</p> <p>Liquid temperature range: -25 .. 120 °C</p> <p>Selected liquid temperature: 20 °C</p> <p>Density: 998.2 kg/m³</p> <p>Technical:</p> <p>Pump speed on which pump data are based: 2870 rpm</p> <p>Rated flow: 16 m³/h</p> <p>Rated head: 4.6 m</p> <p>Actual impeller diameter: 74 mm</p> <p>Code for shaft seal: BQQE</p> <p>Curve tolerance: ISO9906:2012 3B2</p> <p>Materials:</p> <p>Pump housing: Cast iron EN-GJL-250 ASTM class 35</p> <p>Impeller: Stainless steel EN 1.4301 AISI 304</p> <p>Installation:</p> <p>Range of ambient temperature: -30 .. 60 °C</p> <p>Maximum operating pressure: 10 bar</p> <p>Max pressure at stated temp: 10 bar / 120 °C</p> <p>Type of connection: DIN</p> <p>Size of connection: DN 50</p> <p>Pressure rating for connection: PN 6/10</p> <p>Port-to-port length: 280 mm</p> <p>Flange size for motor: FT85</p>

Qty.	Description
	Electrical data:
	Motor type: 71A
	IE Efficiency class: IE3
	Rated power - P2: 0.37 kW
	Mains frequency: 50 Hz
	Rated voltage: 3 x 220-240D/380-415Y V
	Rated current: 1.74/1.00 A
	Starting current: 490-530 %
	Cos phi - power factor: 0.80-0.70
	Rated speed: 2850-2880 rpm
	Efficiency: IE3 73,8%
	Motor efficiency at full load: 73.8 %
	Motor efficiency at 3/4 load: 79.0 %
	Motor efficiency at 1/2 load: 75.5 %
	Number of poles: 2
	Enclosure class (IEC 34-5): 55 Dust/Jetting
	Insulation class (IEC 85): F
	Motor No: 85805102
	Others:
	Minimum efficiency index, MEI \geq : 0.60
	Net weight: 24.2 kg
	Gross weight: 27.7 kg
	Shipping volume: 0.08 m ³
	Danish VVS No.: 381813060
	Finnish LVI No.: 4616045
	Norwegian NRF no.: 9043558



Company name: Pump Sales Direct
Created by:
Phone:

Date: 15/06/2022

98182027 TP 50-60/2 A-F-A-BQQE-DX1 50 Hz

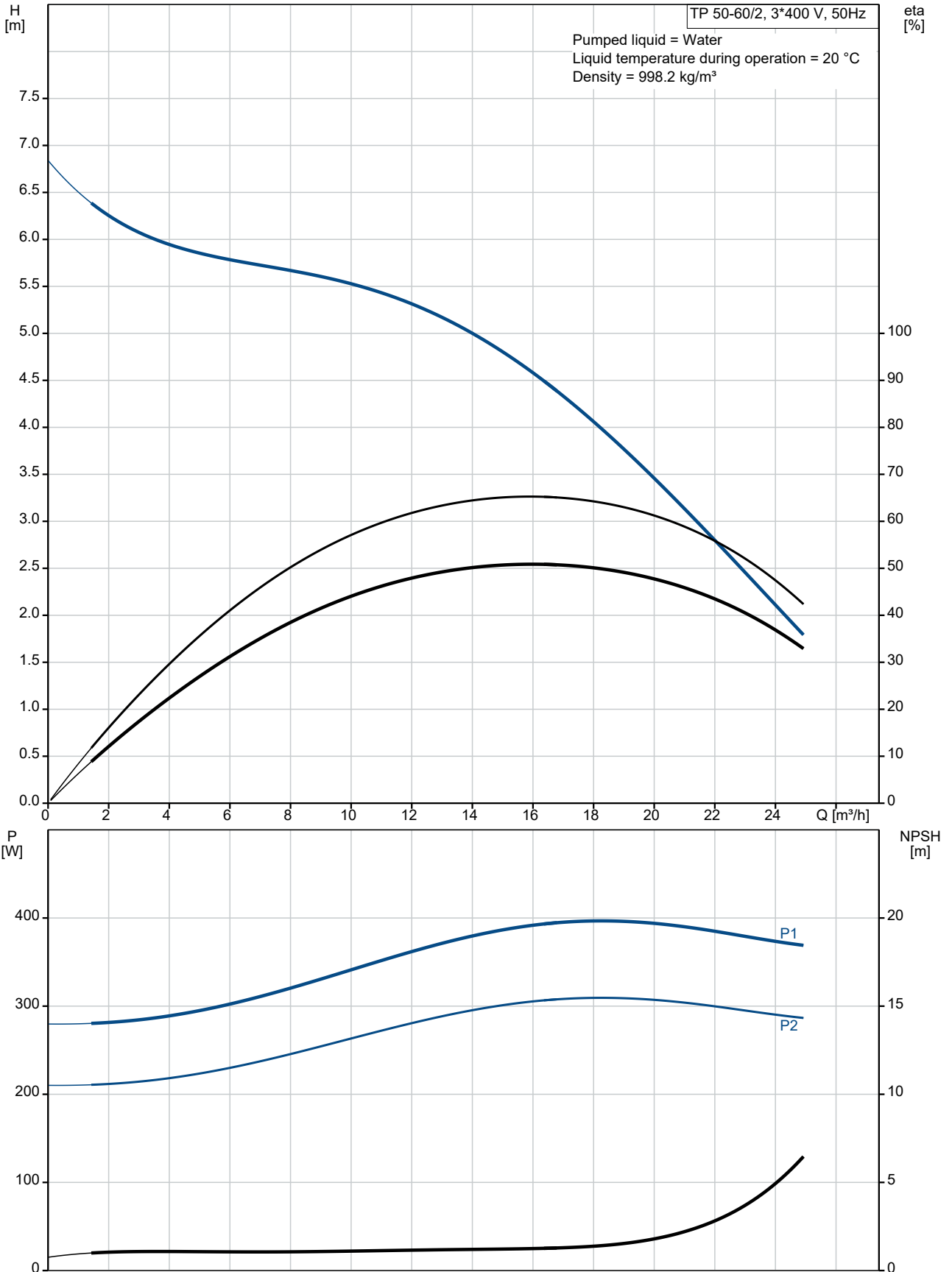

Description	Value
General information:	
Product name:	TP 50-60/2 A-F-A-BQQE-DX1
Product No:	98182027
EAN number:	5711491052083
Technical:	
Pump speed on which pump data are based:	2870 rpm
Rated flow:	16 m ³ /h
Rated head:	4.6 m
Maximum head:	60 dm
Actual impeller diameter:	74 mm
Code for shaft seal:	BQQE
Curve tolerance:	ISO9906:2012 3B2
Pump version:	A
Materials:	
Pump housing:	Cast iron
Pump housing:	EN-GJL-250
Pump housing:	ASTM class 35
Impeller:	Stainless steel
Impeller:	EN 1.4301
Impeller:	AISI 304
Material code:	A
Installation:	
Range of ambient temperature:	-30 .. 60 °C
Maximum operating pressure:	10 bar
Max pressure at stated temp:	10 bar / 120 °C
Type of connection:	DIN
Size of connection:	DN 50
Pressure rating for connection:	PN 6/10
Port-to-port length:	280 mm
Flange size for motor:	FT85
Connect code:	F
Liquid:	
Pumped liquid:	Water
Liquid temperature range:	-25 .. 120 °C
Selected liquid temperature:	20 °C
Density:	998.2 kg/m ³
Electrical data:	
Motor type:	71A
IE Efficiency class:	IE3
Rated power - P2:	0.37 kW
Mains frequency:	50 Hz
Rated voltage:	3 x 220-240D/380-415Y V
Rated current:	1.74/1.00 A
Starting current:	490-530 %
Cos phi - power factor:	0.80-0.70
Rated speed:	2850-2880 rpm
Efficiency:	IE3 73,8%
Motor efficiency at full load:	73.8 %
Motor efficiency at 3/4 load:	79.0 %
Motor efficiency at 1/2 load:	75.5 %
Number of poles:	2
Enclosure class (IEC 34-5):	55 Dust/Jetting
Insulation class (IEC 85):	F
Built-in motor protection:	NONE
Motor No:	85805102
Controls:	

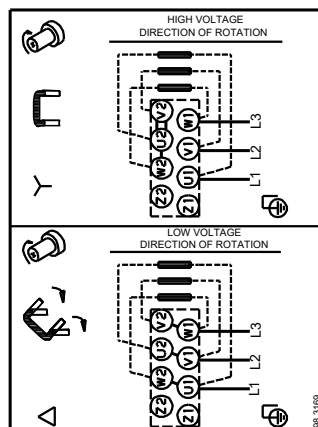
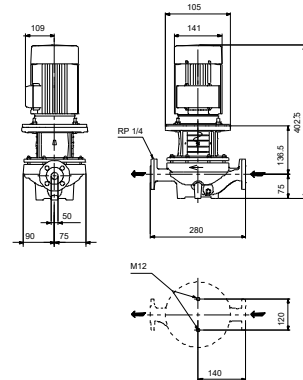
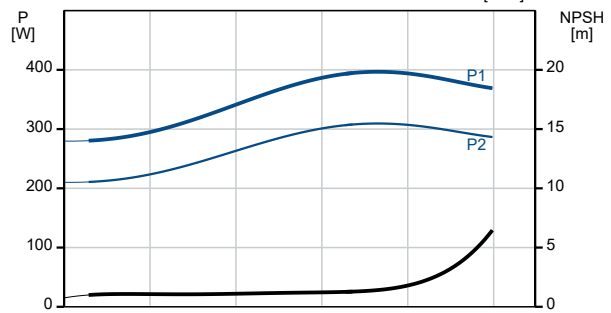
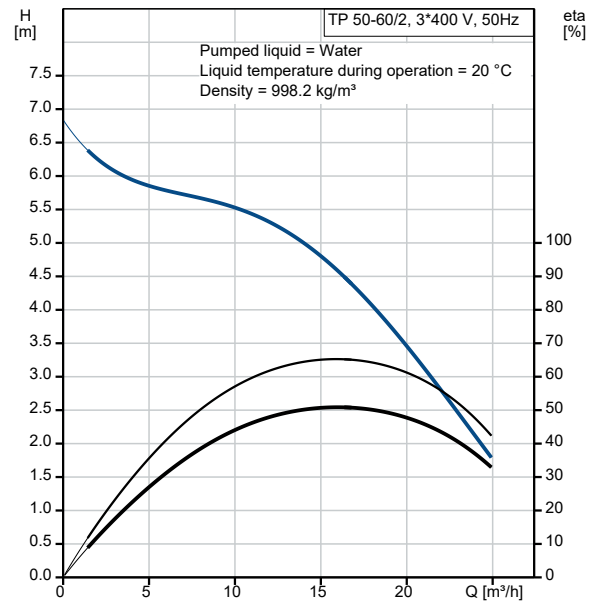



Company name: Pump Sales Direct

Created by:

Phone:

Date: 15/06/2022

Description	Value
Frequency converter:	NONE
Others:	
Minimum efficiency index, MEI ≥:	0.60
Net weight:	24.2 kg
Gross weight:	27.7 kg
Shipping volume:	0.08 m ³
Danish VVS No.:	381813060
Finnish LVI No.:	4616045
Norwegian NRF no.:	9043558



Company name: Pump Sales Direct
Created by:
Phone:

Date: 15/06/2022

98182027 TP 50-60/2 A-F-A-BQQE-DX1 50 Hz

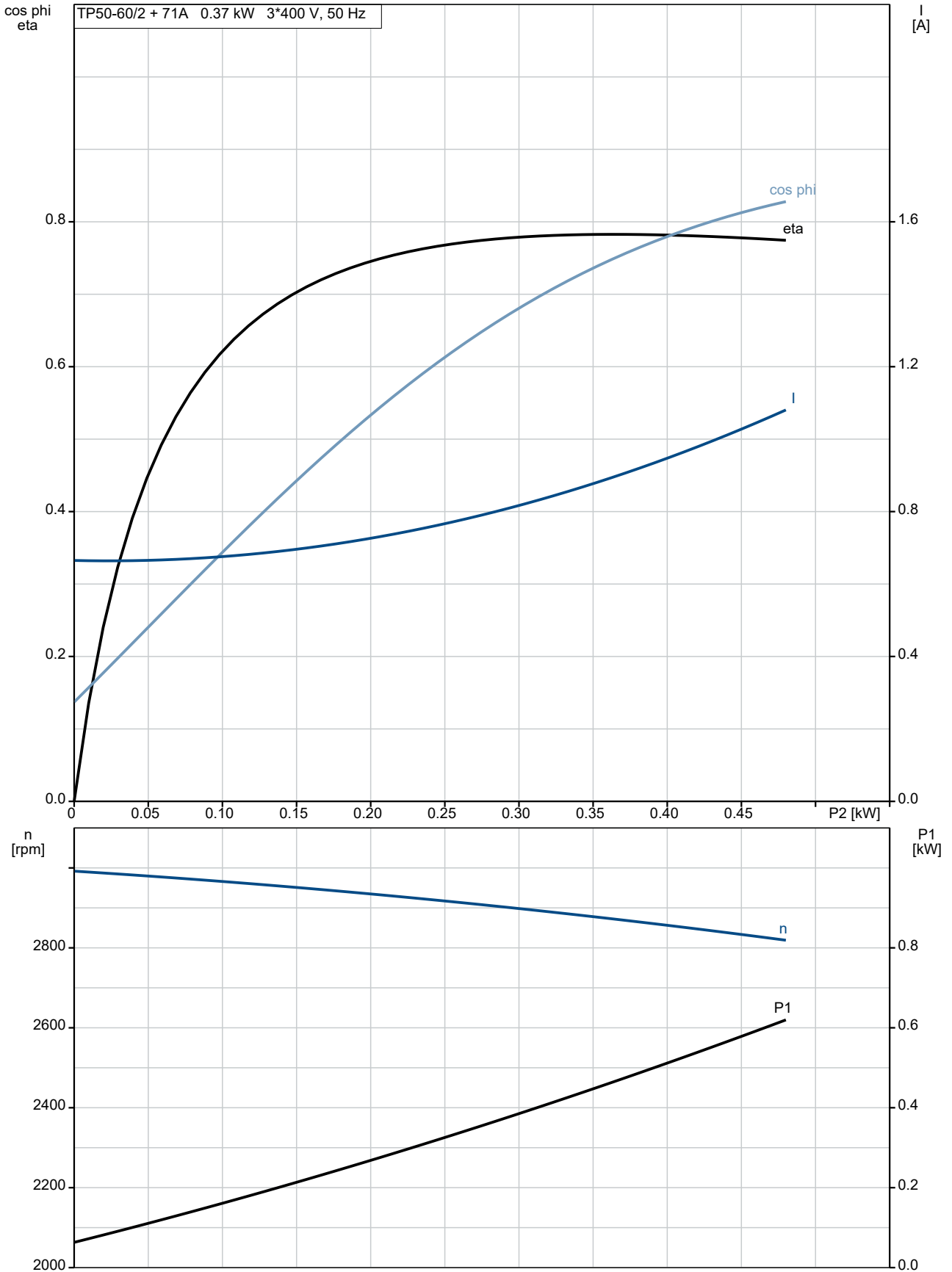

98182027 TP 50-60/2 A-F-A-BQQE-DX1 50 Hz

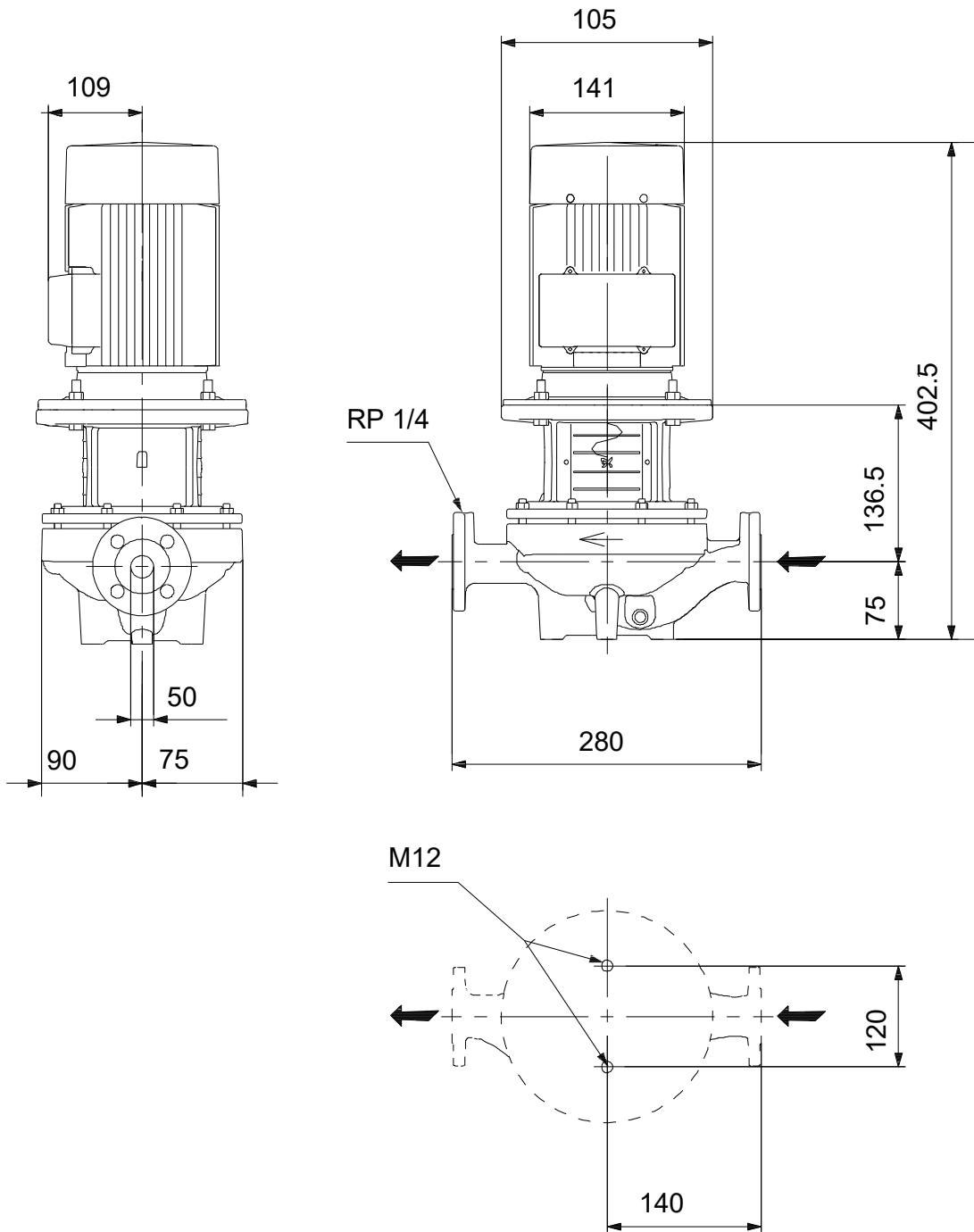

Note! All units are in [mm] unless others are stated.
Disclaimer: This simplified dimensional drawing does not show all details.

98182027 TP 50-60/2 A-F-A-BQQE-DX1 50 Hz

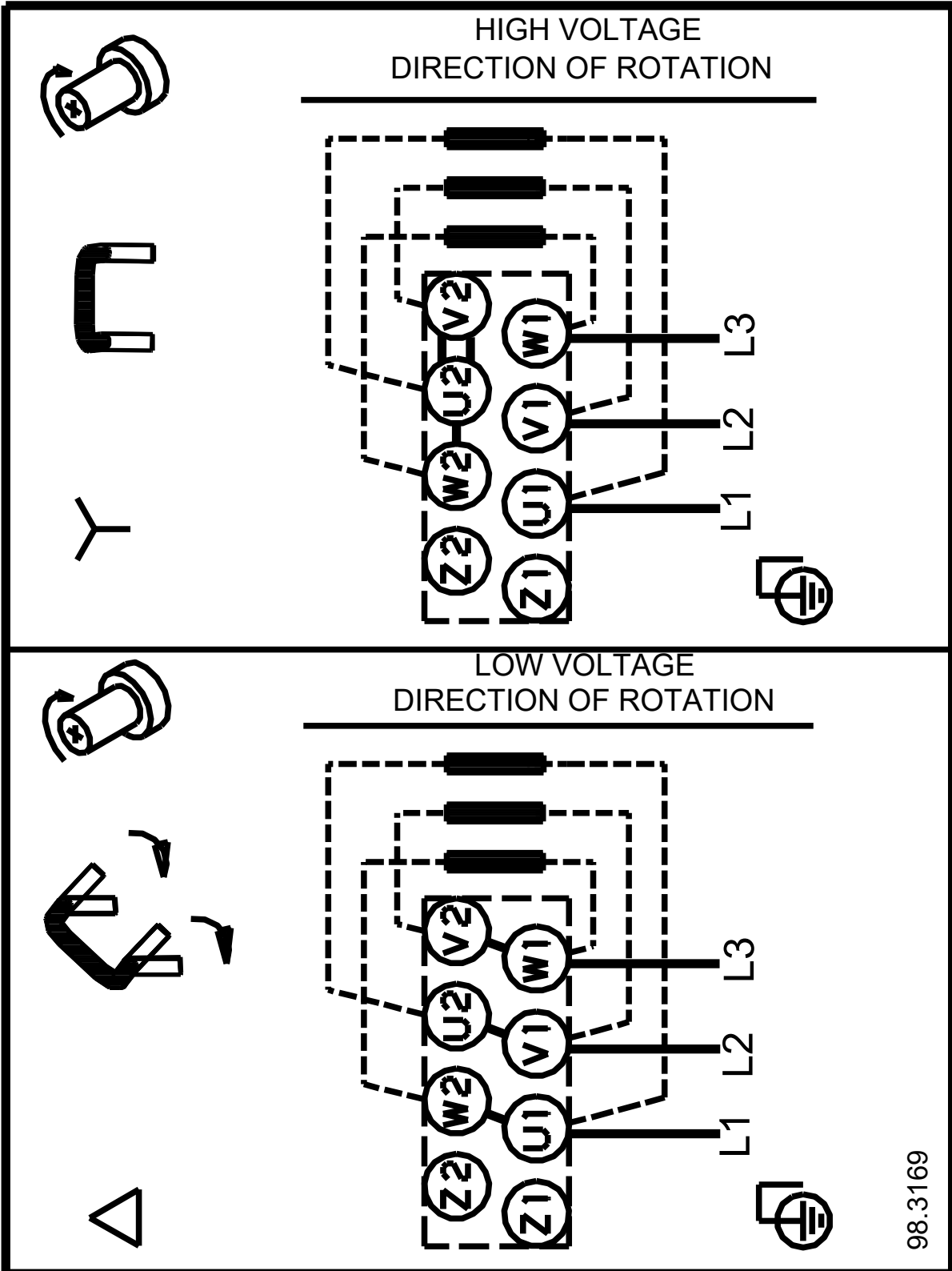

Note! All units are in [mm] unless others are stated.



Company name: Pump Sales Direct

Created by:

Phone:

Date: 15/06/2022

Order Data:

Product name: TP 50-60/2

Amount: 1

Product No: 98182027

Total: Price on request
