

Qty.	Description
1	CRN 10-2 A-FGJ-H-E-HQQE
	
	<p align="center">Note! Product picture may differ from actual product</p>
	<p>Product No.: On request</p>
	<p>Vertical, multistage centrifugal pump with inlet and outlet ports on same the level (inline). Pump materials in contact with the liquid are in high-grade stainless steel. A cartridge shaft seal ensures high reliability, safe handling, and easy access and service. Power transmission is via a rigid split coupling. Pipe connection is via combined DIN-ANSI-JIS flanges.</p>
	<p>The pump is fitted with a 3-phase, fan-cooled asynchronous motor.</p>
	<p>Liquid: Pumped liquid: Water Liquid temperature range: -20 .. 120 °C Selected liquid temperature: 20 °C Density: 998.2 kg/m³</p>
	<p>Technical: Pump speed on which pump data are based: 2864 rpm Rated flow: 10 m³/h Rated head: 15.3 m Pump orientation: Vertical Shaft seal arrangement: Single Code for shaft seal: HQQE Approvals: CE,EAC,UKCA,SEPRO Approvals for drinking water: WRAS,ACS Curve tolerance: ISO9906:2012 3B</p>
	<p>Materials: Base: Stainless steel EN 1.4408 AISI 316 Impeller: Stainless steel EN 1.4401 AISI 316 Bearing: SIC</p>
	<p>Installation: t max amb: 60 °C Maximum operating pressure: 25 bar Max pressure at stated temp: 25 bar / 120 °C 25 bar / -20 °C Type of connection: DIN / ANSI / JIS Size of inlet connection: DN 40 Size of outlet connection: DN 40 Pressure rating for connection: PN 25 Flange rating inlet: 300 lb Flange size for motor: FT100</p>
	<p>Electrical data: Motor standard: IEC Motor type: 80A IE Efficiency class: IE3 Rated power - P2: 0.75 kW Power (P2) required by pump: 0.75 kW Mains frequency: 50 Hz</p>

Qty.	Description
1	<p>Rated voltage: 3 x 220-240D/380-415Y V</p> <p>Rated current: 3.30/1.90 A</p> <p>Starting current: 580-620 %</p> <p>Cos phi - power factor: 0.81-0.71</p> <p>Rated speed: 2840-2870 rpm</p> <p>Efficiency: IE3 80,7%</p> <p>Motor efficiency at full load: 80.7 %</p> <p>Motor efficiency at 3/4 load: 82.7 %</p> <p>Motor efficiency at 1/2 load: 81.7 %</p> <p>Number of poles: 2</p> <p>Enclosure class (IEC 34-5): 55 Dust/Jetting</p> <p>Insulation class (IEC 85): F</p> <p>Motor No: 85U05104</p> <p>Controls:</p> <p>Frequency converter: NONE</p> <p>Others:</p> <p>Minimum efficiency index, MEI \geq 0.70</p> <p>Net weight: 33 kg</p> <p>Gross weight: 37 kg</p> <p>Shipping volume: 0.08 m³</p> <p>Country of origin: GB</p> <p>Custom tariff no.: 84137075</p>

On request CRN 10-2 A-FGJ-H-E-HQQE 50 Hz

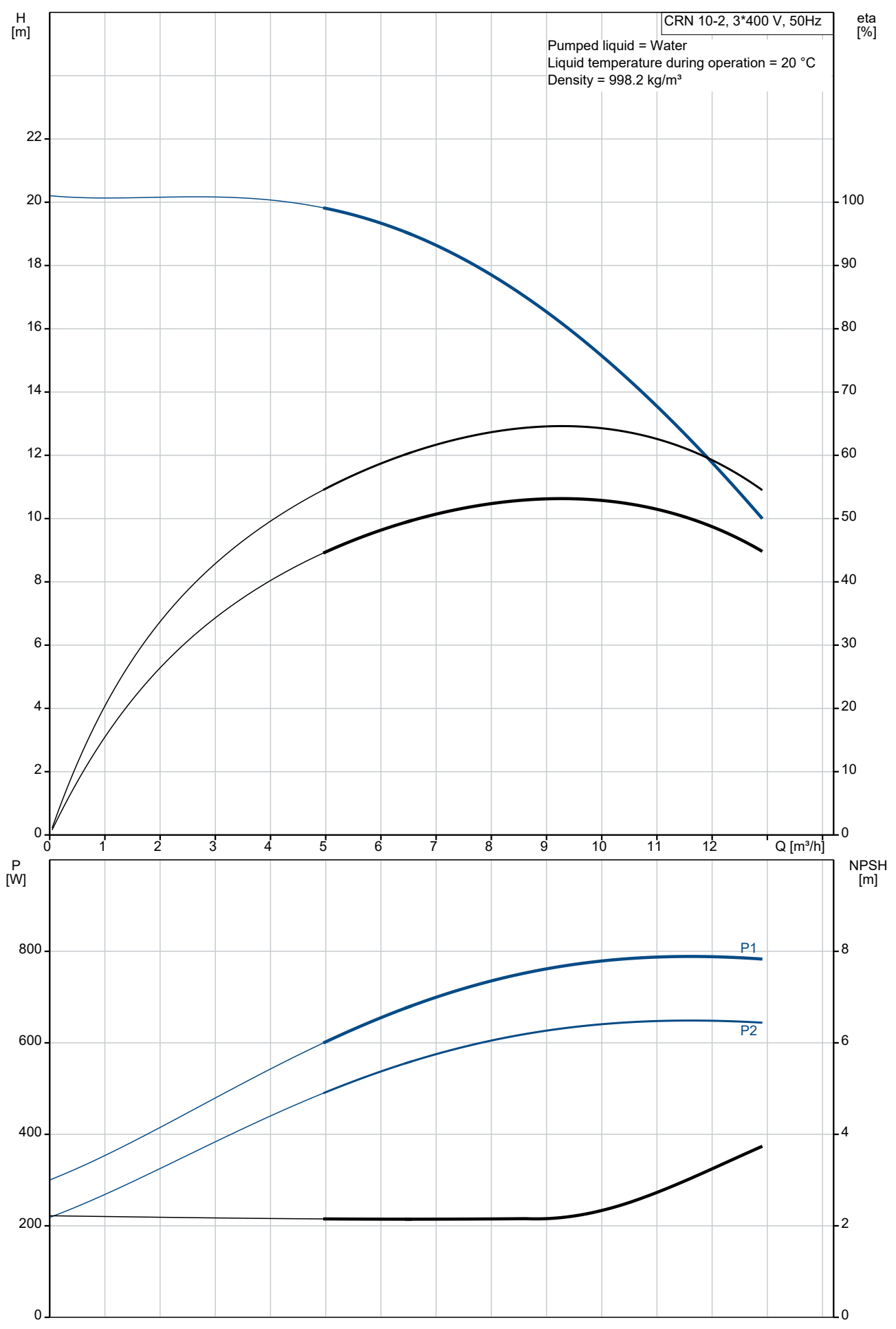

Description	Value
General information:	
Product name:	CRN 10-2 A-FGJ-H-E-HQQE
Product No:	On request
EAN number:	On request
Technical:	
Pump speed on which pump data are based:	2864 rpm
Rated flow:	10 m ³ /h
Rated head:	15.3 m
Maximum head:	20.2 m
Stages:	2
Impellers:	2
Number of reduced-diameter impellers:	0
Low NPSH:	N
Pump orientation:	Vertical
Shaft seal arrangement:	Single
Code for shaft seal:	HQQE
Approvals:	CE,EAC,UKCA,SEPRO
Approvals for drinking water:	WRAS,ACS
Curve tolerance:	ISO9906:2012 3B
Pump version:	A
Model:	A
Materials:	
Base:	Stainless steel
Base:	EN 1.4408
Base:	AISI 316
Impeller:	Stainless steel
Impeller:	EN 1.4401
Impeller:	AISI 316
Material code:	H
Code for rubber:	E
Bearing:	SIC
Installation:	
t max amb:	60 °C
Maximum operating pressure:	25 bar
Max pressure at stated temp:	25 bar / 120 °C
Max pressure at stated temp:	25 bar / -20 °C
Type of connection:	DIN / ANSI / JIS
Size of inlet connection:	DN 40
Size of outlet connection:	DN 40
Pressure rating for connection:	PN 25
Flange rating inlet:	300 lb
Flange size for motor:	FT100
Connect code:	FGJ
Liquid:	
Pumped liquid:	Water
Liquid temperature range:	-20 .. 120 °C
Selected liquid temperature:	20 °C
Density:	998.2 kg/m ³
Electrical data:	
Motor standard:	IEC
Motor type:	80A
IE Efficiency class:	IE3
Rated power - P2:	0.75 kW
Power (P2) required by pump:	0.75 kW
Mains frequency:	50 Hz
Rated voltage:	3 x 220-240D/380-415Y V
Rated current:	3.30/1.90 A
Starting current:	580-620 %
Cos phi - power factor:	0.81-0.71
Rated speed:	2840-2870 rpm
Efficiency:	IE3 80,7%
Motor efficiency at full load:	80.7 %

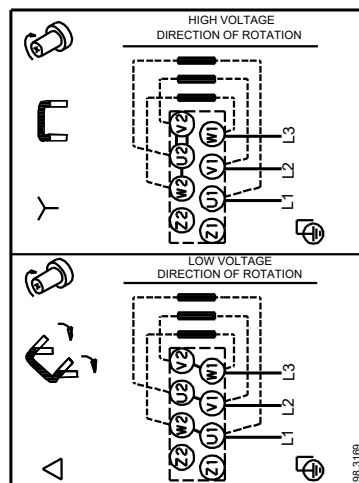
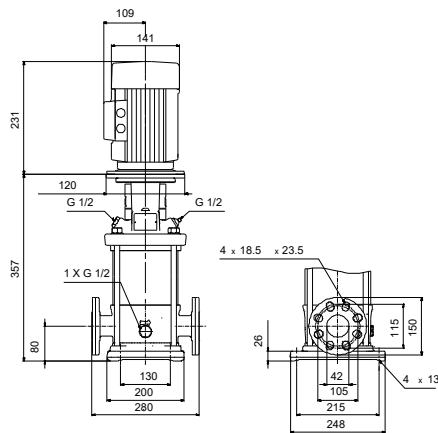
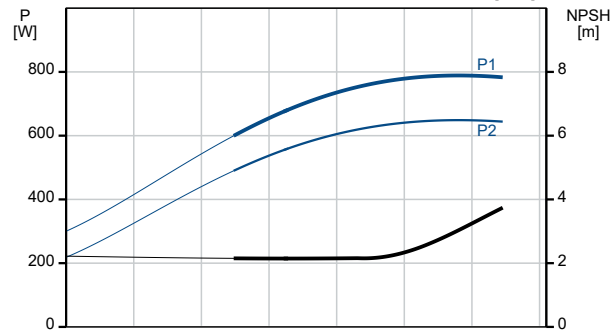
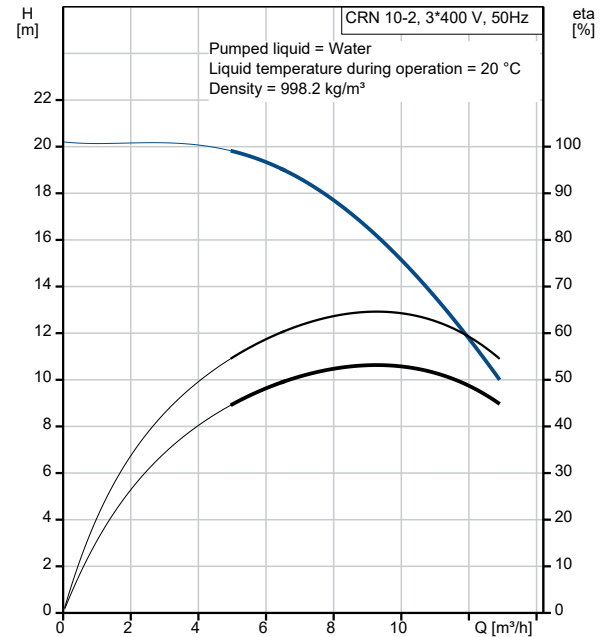

Description	Value
Motor efficiency at 3/4 load:	82.7 %
Motor efficiency at 1/2 load:	81.7 %
Number of poles:	2
Enclosure class (IEC 34-5):	55 Dust/Jetting
Insulation class (IEC 85):	F
Built-in motor protection:	NONE
Motor No:	85U05104
Controls:	
Frequency converter:	NONE
Others:	
Minimum efficiency index, MEI ≥:	0.70
Net weight:	33 kg
Gross weight:	37 kg
Shipping volume:	0.08 m ³
Sales region:	Great Britain
Country of origin:	GB
Custom tariff no.:	84137075

On request CRN 10-2 A-FGJ-H-E-HQQE 50 Hz

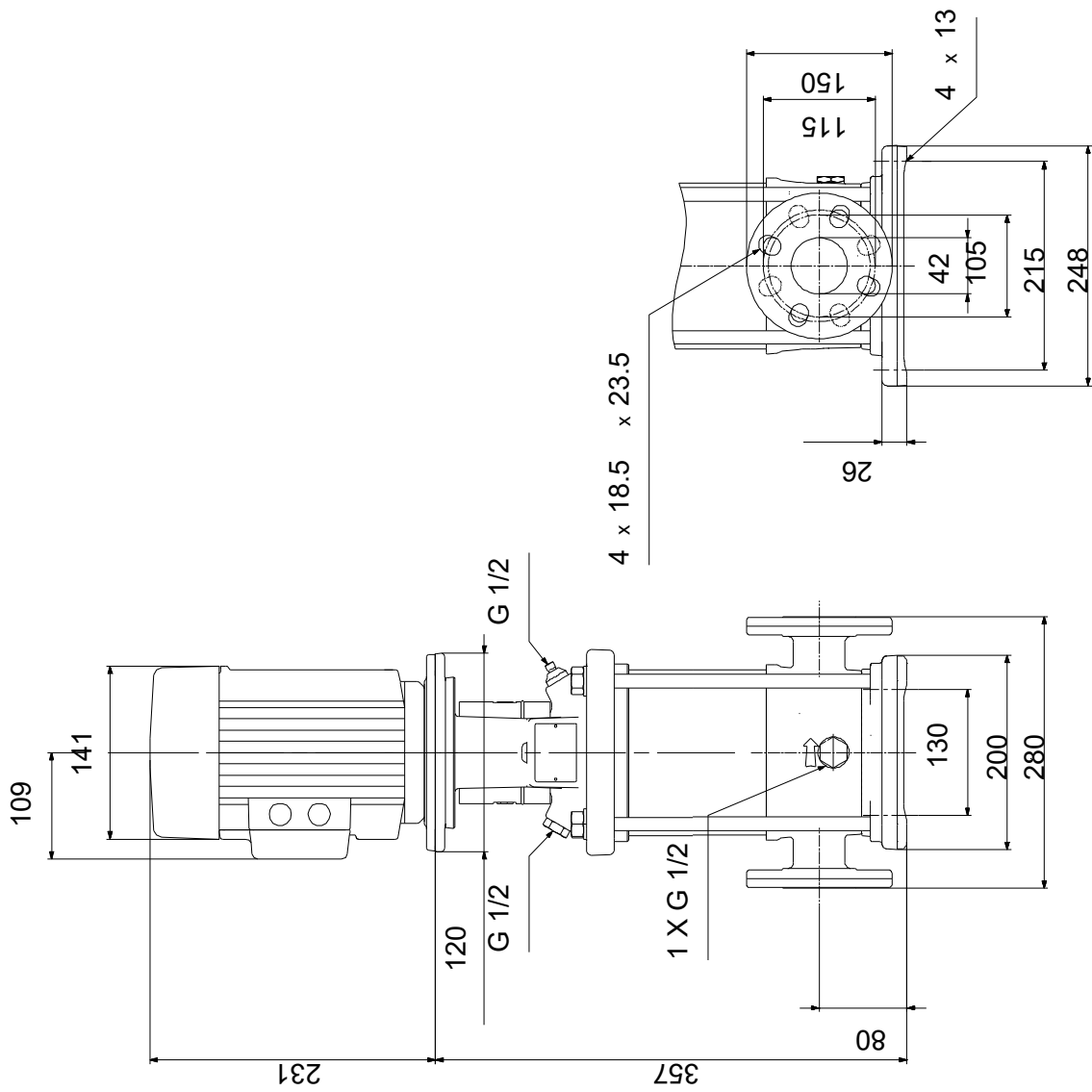

Note! All units are in [mm] unless others are stated.
Disclaimer: This simplified dimensional drawing does not show all details.

On request CRN 10-2 A-FGJ-H-E-HQQE 50 Hz

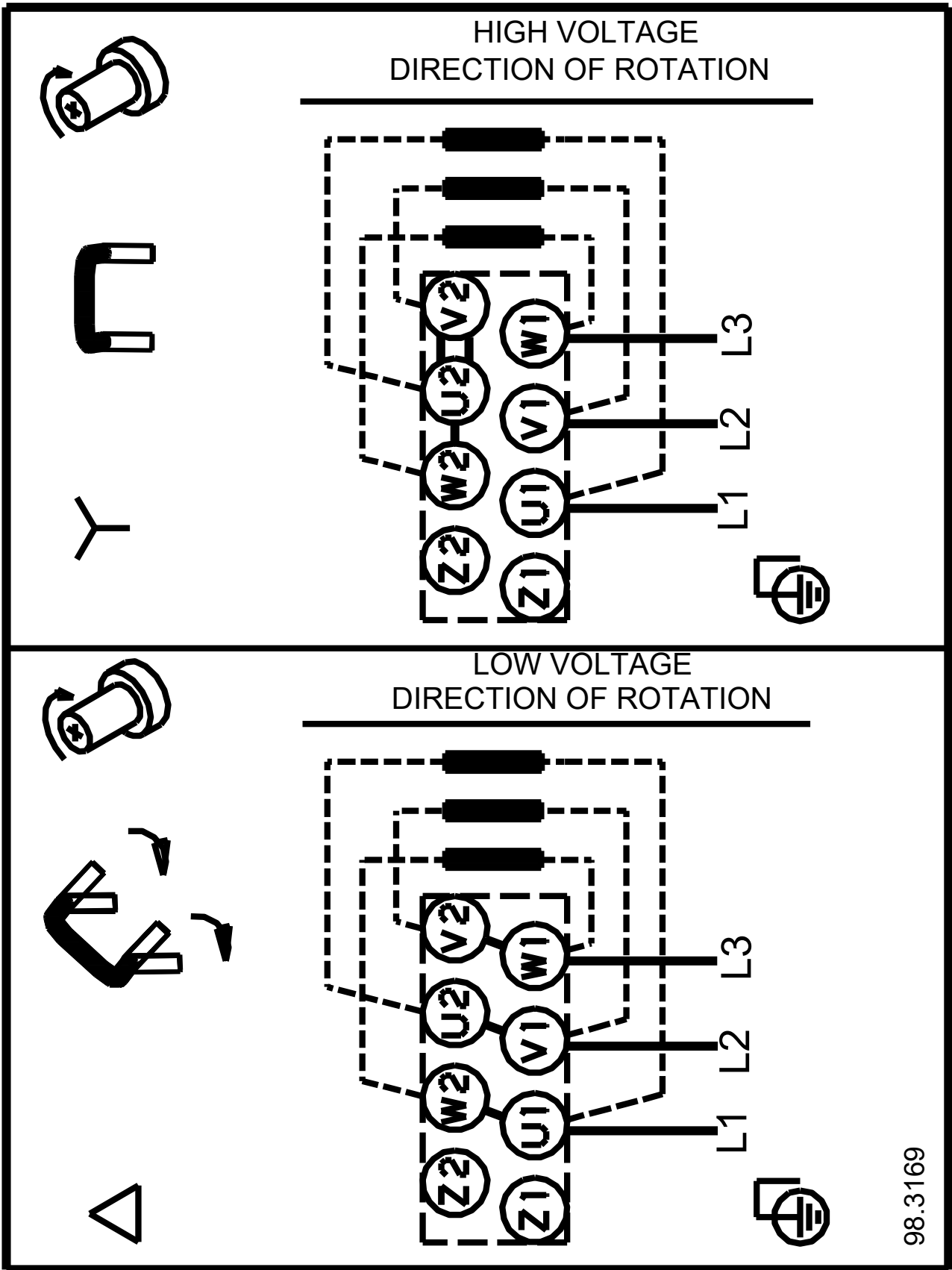

Note! All units are in [mm] unless others are stated.

