

Qty. Description

1 TP 200-660/4 A-F-A-BQQE-2X3



Note! Product picture may differ from actual product

Product No.: On request

Single-stage, close-coupled, volute pump with in-line suction and discharge ports of identical diameter.

The pump is of the top-pull-out design, i.e. the power head (motor, pump head and impeller) can be removed for maintenance or service while the pump housing remains in the pipework.

The pump is fitted with an unbalanced rubber bellows seal.

The shaft seal is according to EN 12756. Pipework connection is via PN 16 DIN flanges (EN 1092-2 and ISO 7005-2).

The pump is fitted with a fan-cooled asynchronous motor.

The product's minimum efficiency index (MEI) is greater or equal to 0.70. This is by the Commission Regulation (EU) considered as an indicative benchmark for best-performing water pump available on the market as from 1 January 2013.

Cast-iron parts have an epoxy-based coating made in a cathodic electro-deposition (CED) process. CED is a high-quality dip-painting process where an electrical field around the products ensures deposition of paint particles as a thin, well-controlled layer on the surface.

Pump

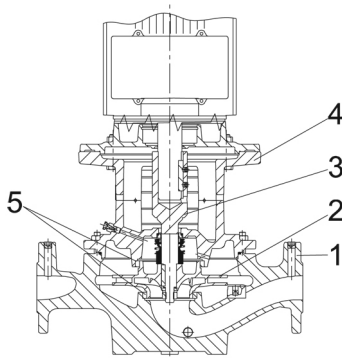

1: Pump housing

2: Impeller

3: Stub shaft

4: Pump head/motor stool

5: Wear rings

The pump housing is provided with a replaceable brass neck ring to reduce the amount of liquid running from the outlet side of the impeller to the inlet side.

The impeller is secured to the shaft with a nut.

The pump is fitted with an unbalanced rubber bellows seal with torque transmission across the spring and around the bellows. Due to the bellows, the seal does not wear the shaft, and the axial movement is not prevented by deposits on the shaft.

Seal faces:

- Rotating seal ring material: silicon carbide (SiC)
- Stationary seat material: silicon carbide (SiC)

This material pairing is used where higher corrosion resistance is required. The high hardness of this material pairing offers good resistance against abrasive particles.

Qty.	Description
	<p>Secondary seal material: EPDM (ethylene-propylene rubber) EPDM has excellent resistance to hot water. EPDM is not suitable for mineral oils. A circulation of liquid through the duct of the air vent screw ensures lubrication and cooling of the shaft seal. The flanges have tappings for mounting of pressure gauges. The motor stool forms connection between the pump housing and the motor, and is equipped with a manual air vent screw for venting of the pump housing and the shaft seal chamber. The sealing between motor stool and pump housing is an O-ring. The central part of the motor stool is provided with guards for protection against the shaft and coupling. The pump shaft is fastened directly on the motor shaft with key and set screws.</p> <p>Motor</p> <p>The motor is a totally enclosed, fan-cooled motor with principal dimensions to IEC and DIN standards. Electrical tolerances comply with IEC 60034. The motor is flange-mounted with free-hole flange (FF). Motor-mounting designation in accordance with IEC 60034-7: IM B 5, IM V 1 (Code I) / IM 3001, IM 3011 (Code II).</p> <p>The motor efficiency is classified as IE3 in accordance with IEC 60034-30-1. The motor has thermistors (PTC sensors) in the windings in accordance with DIN 44081/DIN 44082. The protection reacts to both slow- and quick-rising temperatures, e.g. constant overload and stalled conditions. Thermal switches must be connected to an external control circuit in a way which ensures that the automatic reset cannot cause accidents. The motors must be connected to a motor-protective circuit breaker according to local regulations. A variable speed drive makes adjustment of pump performance to any duty point possible. If the motor is to be connected to a variable speed drive, the pump must be ordered with an electrically insulated motor bearing.</p> <p>Further product details</p> <p>Cast-iron parts have an epoxy-based coating made in a cathodic electro-deposition (CED) process. CED is a high-quality dip-painting process where an electrical field around the products ensures deposition of paint particles as a thin, well-controlled layer on the surface.</p> <p>Technical data</p> <p>Controls: Frequency converter: NONE</p> <p>Liquid: Pumped liquid: Water Liquid temperature range: -25 .. 120 °C Selected liquid temperature: 20 °C Density: 998.2 kg/m³</p> <p>Technical: Pump speed on which pump data are based: 1490 rpm Rated flow: 634 m³/h Rated head: 57 m Actual impeller diameter: 432 mm Code for shaft seal: BQQE Curve tolerance: ISO9906:2012 3B</p> <p>Materials: Pump housing: Cast iron EN-GJL-250 ASTM class 35 Impeller: Cast iron EN-GJL-200 ASTM class 30</p> <p>Installation:</p>

Qty.	Description
	<p>Range of ambient temperature: -20 .. 55 °C</p> <p>Maximum operating pressure: 16 bar</p> <p>Max pressure at stated temp: 16 bar / 120 °C</p> <p>Type of connection: DIN</p> <p>Size of connection: DN 200</p> <p>Pressure rating for connection: PN 16</p> <p>Port-to-port length: 1000 mm</p> <p>Flange size for motor: FF600</p> <p>Electrical data:</p> <p>Motor type: SIEMENS</p> <p>IE Efficiency class: IE3</p> <p>Rated power - P2: 132 kW</p> <p>Mains frequency: 50 Hz</p> <p>Rated voltage: 3 x 380-420D/660-725Y V</p> <p>Rated current: 230/133 A</p> <p>Starting current: 730-730 %</p> <p>Cos phi - power factor: 0.87</p> <p>Rated speed: 1490 rpm</p> <p>Efficiency: IE3 95,6%</p> <p>Motor efficiency at full load: 95.6-95.6 %</p> <p>Motor efficiency at 3/4 load: 95.9-95.9 %</p> <p>Motor efficiency at 1/2 load: 95.9-95.9 %</p> <p>Number of poles: 4</p> <p>Enclosure class (IEC 34-5): IP55</p> <p>Insulation class (IEC 85): F</p> <p>Motor No: 83V15246</p> <p>Others:</p> <p>Minimum efficiency index, MEI ≥: 0.70</p> <p>Net weight: 1500 kg</p> <p>Gross weight: 1670 kg</p> <p>Shipping volume: 3.55 m³</p> <p>Danish VVS No.: 381719660</p> <p>Finnish LVI No.: 4616182</p> <p>Country of origin: HU</p> <p>Custom tariff no.: 84137051</p>

On request TP 200-660/4 A-F-A-BQQE-2X3 50 Hz

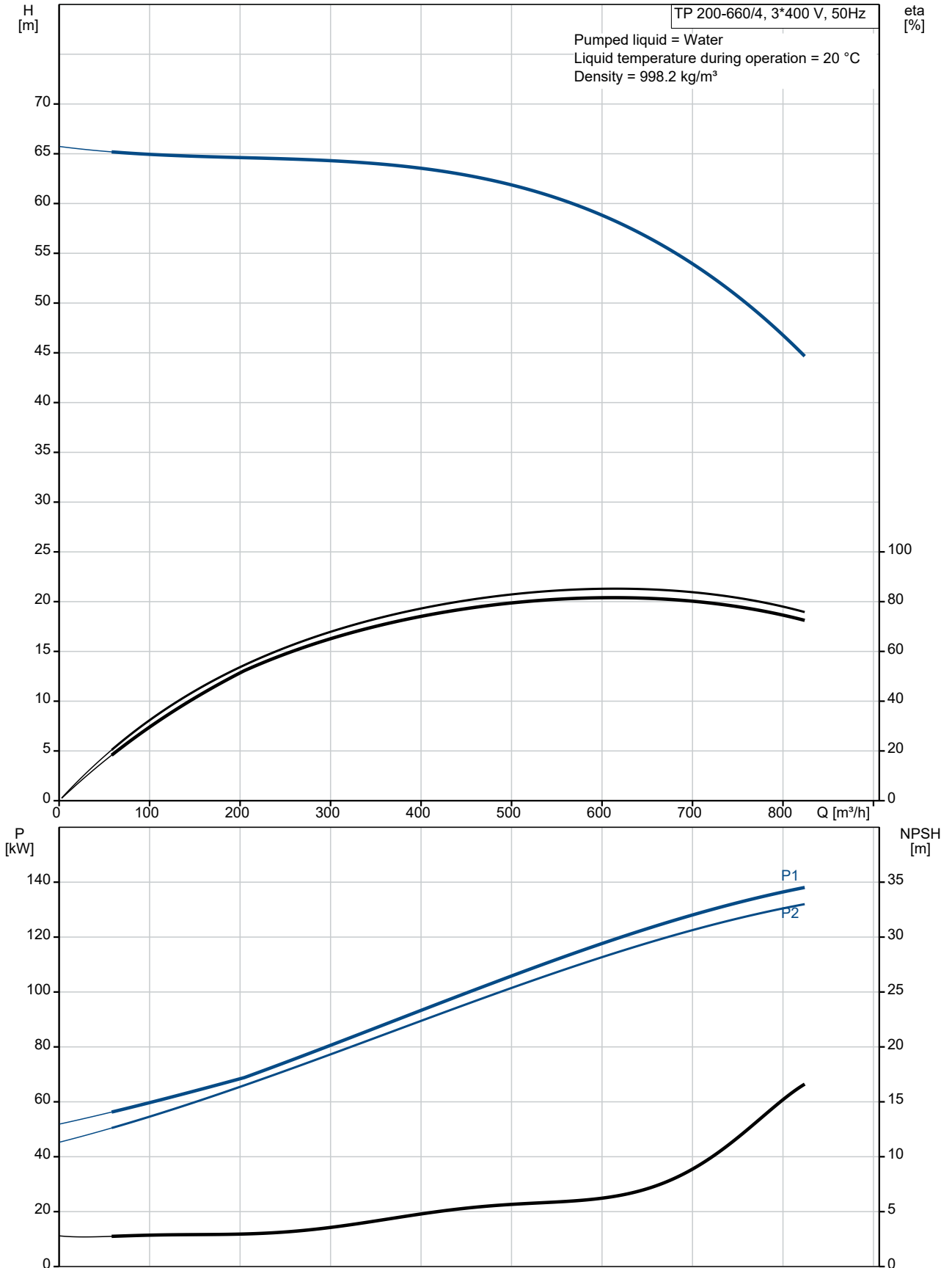

Description	Value
General information:	
Product name:	TP 200-660/4 A-F-A-BQQE-2X3
Product No:	On request
EAN number:	On request
Technical:	
Pump speed on which pump data are based:	1490 rpm
Rated flow:	634 m ³ /h
Rated head:	57 m
Maximum head:	660 dm
Actual impeller diameter:	432 mm
Code for shaft seal:	BQQE
Curve tolerance:	ISO9906:2012 3B
Pump version:	A
Materials:	
Pump housing:	Cast iron
Pump housing:	EN-GJL-250
Pump housing:	ASTM class 35
Impeller:	Cast iron
Impeller:	EN-GJL-200
Impeller:	ASTM class 30
Material code:	A
Installation:	
Range of ambient temperature:	-20 .. 55 °C
Maximum operating pressure:	16 bar
Max pressure at stated temp:	16 bar / 120 °C
Type of connection:	DIN
Size of connection:	DN 200
Pressure rating for connection:	PN 16
Port-to-port length:	1000 mm
Flange size for motor:	FF600
Connect code:	F
Liquid:	
Pumped liquid:	Water
Liquid temperature range:	-25 .. 120 °C
Selected liquid temperature:	20 °C
Density:	998.2 kg/m ³
Electrical data:	
Motor type:	SIEMENS
IE Efficiency class:	IE3
Rated power - P2:	132 kW
Mains frequency:	50 Hz
Rated voltage:	3 x 380-420D/660-725Y V
Rated current:	230/133 A
Starting current:	730-730 %
Cos phi - power factor:	0.87
Rated speed:	1490 rpm
Efficiency:	IE3 95,6%
Motor efficiency at full load:	95.6-95.6 %
Motor efficiency at 3/4 load:	95.9-95.9 %
Motor efficiency at 1/2 load:	95.9-95.9 %
Number of poles:	4
Enclosure class (IEC 34-5):	IP55
Insulation class (IEC 85):	F
Built-in motor protection:	PTC
Motor No:	83V15246
Controls:	
Frequency converter:	NONE

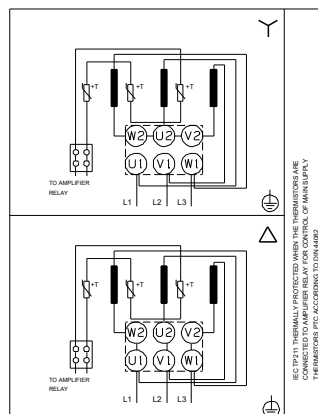
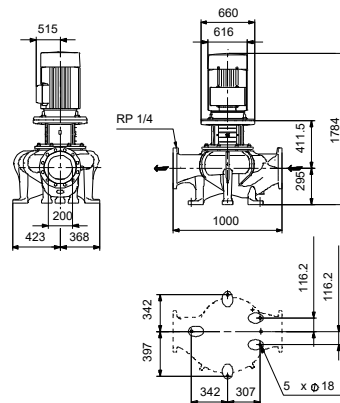
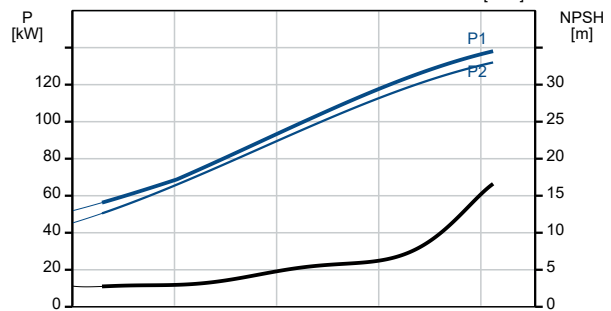
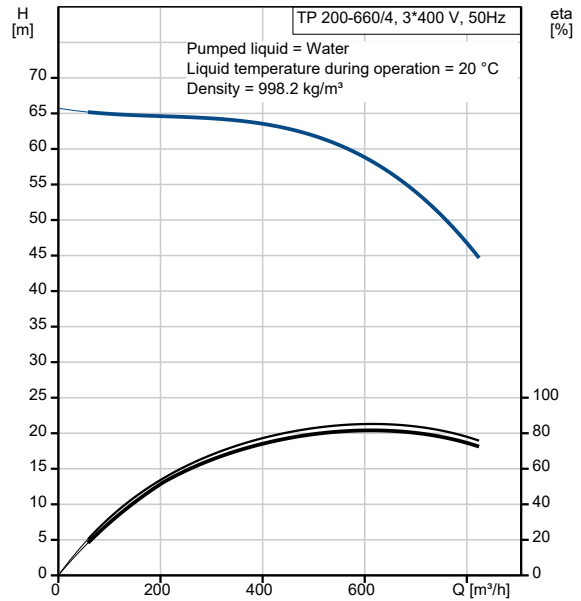



Company name:

Created by:

Phone:

Date:

16/06/2022

Description	Value
Others:	
Minimum efficiency index, MEI ≥:	0.70
Net weight:	1500 kg
Gross weight:	1670 kg
Shipping volume:	3.55 m ³
Danish VVS No.:	381719660
Finnish LVI No.:	4616182
Country of origin:	HU
Custom tariff no.:	84137051

On request TP 200-660/4 A-F-A-BQQE-2X3 50 Hz

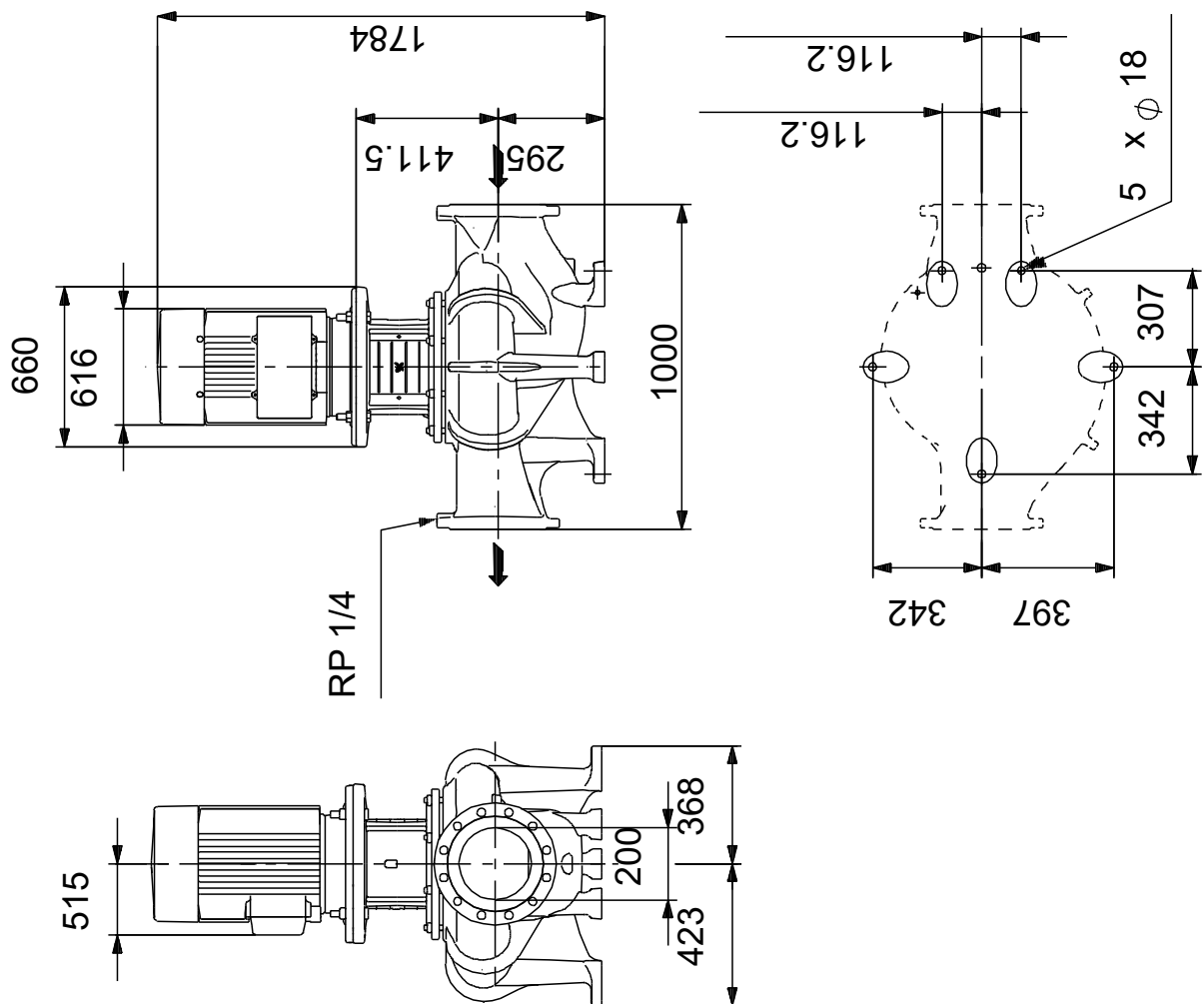

Note! All units are in [mm] unless others are stated.
Disclaimer: This simplified dimensional drawing does not show all details.

On request TP 200-660/4 A-F-A-BQQE-2X3 50 Hz



IEC TP211 THERMALLY PROTECTED WHEN THE THERMISTORS ARE
CONNECTED TO AMPLIFIER RELAY FOR CONTROL OF MAIN SUPPLY
THERMISTORS PTC ACCORDING TO DIN 44082

Note! All units are in [mm] unless others are stated.



Company name:

Created by:

Phone:

Date:

16/06/2022

Order Data:

Product name: TP 200-660/4

Amount: 1

Product No: On request

Total: Price on request
