

The MultiSkin Metallic Press fittings for multilayer pipe.

- A range of metal fittings from 14 to 75 mm.
- MultiSkin press fittings are compatible with TH, H and U profiles.
- Immediate verification of crimping with the Visu-Control ring.
- Low pressure loss across the fittings.

Advantages

Performance

- Press connections can be done in seven seconds and this type of connection avoids the risks associated with welding.
- MultiSkin press fittings are compatible with TH, H and U profiles, and therefore with different tool brands.
- Improved hydraulics with a reduction of pressure losses of 17% on average compared to former products.

Safety

- Removable Visu-Control® ring, allowing visual and tactile control of a crimp.
- The "not crimped, not sealed" technology: if not crimped, the fitting allows water to pass during the pressure test.
- Protective cap to prevent impurities from penetrating.

Technical Specifications

MultiSkin system is designed for the following applications:

- Sanitary water: +5 °C to +95 °C (operating temperature) and 10 bar (maximum operating pressure).
- Heating and cooling: -10 °C to +95 °C (operating temperature) and 10 bar (maximum operating pressure).
- Rainwater: -10 °C to +95 °C (operating temperature) and 10 bar (maximum operating pressure).

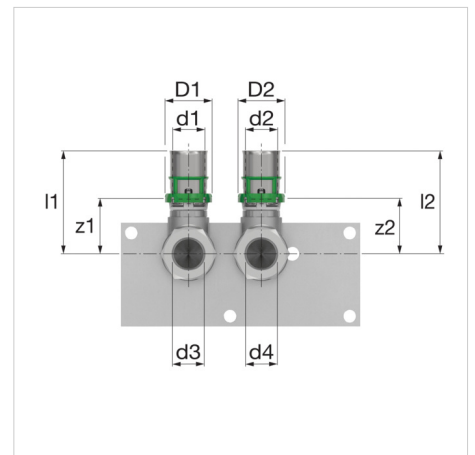

Description	Support with 2 wall plates and compression copper Cu 15 16x2 - H73 - Ia35
Order Code	7506W16153
GTIN	03430650463646
Model	<u>7506W - Support with 2 wall plates and compression copper</u>
Dimensions	Cu 15 16x2 - H73 - Ia35

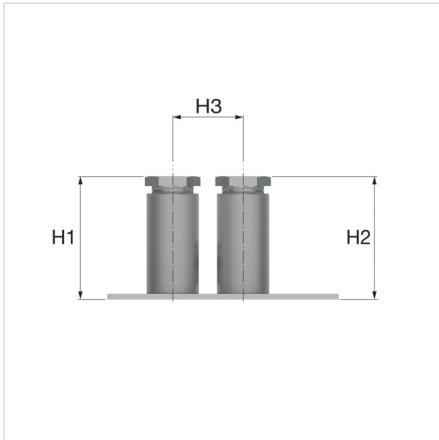

Dimensions Support with 2 wall plates and compression copper - 7506W

Type	Dimensions												
	d1 [mm]	d2 [mm]	d3 [mm]	d4 [mm]	D1 [mm]	D2 [mm]	z1 [mm]	z2 [mm]	l1 [mm]	l2 [mm]	H1 [mm]	H2 [mm]	H3 [mm]
Support with 2 wall plates and compression copper Cu 15 16x2 - H61 - Ia35	16	16	15	15	23	23	26	26	50	50	61	61	35
Support with 2 wall plates and compression copper Cu 15 16x2 - H61 - Ia50	16	16	15	15	23	23	26	26	50	50	61	61	50
Support with 2 wall plates and compression copper Cu 15 16x2 - H73 - Ia35	16	16	15	15	23	23	26	26	50	50	73	73	35
Support with 2 wall plates and compression copper Cu 15 16x2 - H73 - Ia50	16	16	15	15	23	23	26	26	50	50	73	73	50

Classification General Data

Etim Group	Fittings, flanges and connectors
Etim Class	Wall plate on bracket
Product Name	Skinpr Metal - supp. 2 wall plates compr copper - Cu 15 16x2-H73-ia35
Brand	COMAP
Product Type	16x2-15 H73-ia35

Attributes

Double flat
Yes
Brass
Other
Tinned
DN 12
16
Press sleeve
Other
50
26
50
26
115
35
0
10
70
TH/U
Yes
No



Find more information online:

[Installation and operating instructions](#)

[ACS certificate](#)

[DVGW certificate](#)

[DVGW certificate of conformity](#)

[KIWA certificate](#)

[NF certificate](#)

[WRAS certificate](#)

[PZH certificate](#)

[PZH certificate MultiSkin2](#)

[PZH certificate MultiSkin4](#)

[MultiSkin ÉMI certificate HUN](#)

[7506W RFA](#)

[7506W DWG](#)

[7506W STEP](#)

[Leaflet](#)

[Installation and operating instructions](#)

[ACS certificate](#)

[DVGW certificate](#)

[DVGW certificate of conformity](#)

[KIWA certificate](#)

[NF certificate](#)

[WRAS certificate](#)

[PZH certificate](#)

[PZH certificate MultiSkin2](#)

[PZH certificate MultiSkin4](#)

[MultiSkin ÉMI certificate HUN](#)

[7506W RFA](#)

[7506W DWG](#)

[7506W STEP](#)

[Leaflet](#)

Washway Lane

UK-WA10 6PB, St Helens, Merseyside - gb

T +44 17 447 447 44

E uk.info@aalberts-hfc.com

I flamcogroup.com/uk-en